

97570

Combination Conservation Vent & Flame Arrester

SHAND & JUR'S

97570 Combination Conservation Vent & Flame Arrester

The Shand and Jurs Model 97570 is a combination of our 94020 Conservation Vent and 94306 Flame Arrester in a single, easy to configure package providing for pressure and vacuum relief, as well as positive flame stop on low pressure tanks containing flammable liquids or solvents having a low flash point.

Continued design improvements provide the 94020 conservation vent with high efficiency, maximum flow capacity and minimum leakage. Standard materials of construction are low copper aluminum, cast iron, ductile iron, cast steel and 316 stainless steel for body materials. The conservation vent features air cushion seated diaphragms constructed of FEP for reliability, and extended service life. For high reliability, the pressure and vacuum pallets are both peripherally and center stem guided. Conservation Vents are available in a full range of sizes and configurations, such as open or closed vent (pipe-away). Standard pressure and vacuum settings are 1/2 oz./sq. in.

The 94306 not only provides exceptional protection against fire from external ignition, but also offers maximum flow capacity. The unitized tube bank provides maximum flow while minimizing pressure drop. Standard construction includes light weight cast aluminum, cast iron, cast steel, 304 stainless steel and 316 stainless steel body materials suitable for most environments. Tube bank is available in aluminum, 304 stainless steel and 316 stainless steel as standard. For highly corrosive and severe conditions, special materials and coatings are available. A complete range of sizes from 2" through 12" are available with flat face or raised face flanges to match ANSI 150 lb. connections.

Expanda-Seal

Shand & Jurs "Expanda-Seal" option is available on all pressure pallet assemblies. This feature significantly reduces leakage. The ballooning effect of the FEP diaphragm effectively seals the valve.

The "Expanda-Seal" feature ensures less than .5 SCFH of air at 95% of the set point.

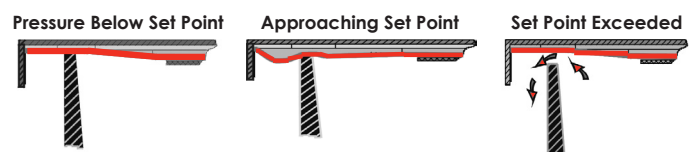

Features

- Sizes 2" thru 12" ANSI, EN1092-1, JIS 10K
- Cost effective, dual purpose
- Provides pressure & vacuum relief
- Serves as a barrier between external flame and internal vapors
- Provides protection against flame propagation
- Optional "all weather" coating and insulation jackets available
- Open or closed vent configurations

SHAND & JUR'S

5911 Butterfield Road Hillside, IL 60162 • tel: (708) 236-6000 • fax: (708) 236-6006
sales@ljtechnologies.com • www.ljtechnologies.com • ISO 9001:2015 Certified

Rev: 97570-3I

94020 Specifications

Sizes:

2", 3", 4", 6", 8", 10" & 12"

Settings:

Standard Pressure & Vacuum: 1/2 oz./in.² (.865 in. W.C.)

Expanda-Seal Pressure Setting:

1.5 oz./in.² Minimum (Consult Factory for lower settings)

Maximum Setting W/O Modification:

	(Pressure)	(Vacuum)**
2":	16 oz./in. ²	8 oz./in. ²
3":	16 oz./in. ²	9 oz./in. ²
4":	16 oz./in. ²	11 oz./in. ²
6":	12 oz./in. ²	12 oz./in. ²
8":	10 oz./in. ²	14 oz./in. ²
10":	8 oz./in. ²	16 oz./in. ²
12":	6 oz./in. ²	16 oz./in. ²

Temperature Range:

Body and Seal -40°F to 220°F. Options for Process
Temperature Ranges of -300°F to 500°F

Diaphragm:

FEP (Fluorinated Ethylene Propylene), FKM (Fluoroelastomer),
NBR (Nitrile-Butadiene), PFA (Fluoroplastic Film)

Service and Body Material:

Normal: Cast Low Copper Aluminum
Low Temperature: Cast Low Copper Aluminum
Severe: Cast Steel, Cast 316 Stainless Steel
Integral Seats: Same as body; AL, 316 SS, CS with 316
Stainless Steel seat overlay

Replaceable Seats:

Aluminum, 316 Stainless Steel, 316 SS Teflon Coated

Type of Flange Connection:

Screwed or flanged for: 2" & 3" sizes
Flanged for: 4", 6", 8", 10" & 12" sizes
Raised face flange available, except for aluminum body material.

Options Available:

Flame Snuffer for all sizes (open vent) and material, except low
temperature service. Closed vent for all sizes and materials.
Material substitutions as required. Cleaning for LOX/LIN service.

94020 Standard Materials of Construction

Component	Normal Aluminum	Low Temperature		
Body	Cast Aluminum	Cast Aluminum	Cast Steel	316 Stainless Steel
Cover	Aluminum	Aluminum	Carbon Steel	316 Stainless Steel
Hood	18-8 Stainless Steel ¹	Aluminum ²	18-8 Stainless Steel ¹	316 Stainless Steel
Seats ³	Aluminum	Aluminum	316 Stainless Steel	316 Stainless Steel
Stem Guide	Galvanized Iron	316 Stainless Steel	Galvanized Iron	316 Stainless Steel
Pallets	Aluminum	Aluminum	316 Stainless Steel	316 Stainless Steel
Pressure Stem	316 Stainless Steel	316 Stainless Steel	316 Stainless Steel	316 Stainless Steel
Vacuum Stem	Aluminum ⁴	Aluminum ⁴	316 Stainless Steel	316 Stainless Steel
Screens	Galvanized Steel	304 Stainless Steel	304 Stainless Steel	316 Stainless Steel
Retainer	Aluminum	Aluminum	316 Stainless Steel	316 Stainless Steel
Hardware	Zinc Plated Steel	316 Stainless Steel	316 Stainless Steel	316 Stainless Steel
Diaphragms	FEP	FEP	FEP	FEP

NOTES: 1. 18-8SS for 2", 3", 4", 6" & 8" sizes; spun alum. for 10" & 12" sizes.
2. 2", 3", 4", 6", 8", 10" & 12" sizes ; alum. enclosure w/flapper. 3. Material same as body.
4. 316SS for elevated settings.

94306 Flame Arrester Specifications:

Sizes:

2", 3", 4", 6", 8", 10" and 12"

Max. Static Pressure:

10 PSIG.

Max. Operating Pressure:

1 PSIG.

Flange Rating:

To match drilling of ANSI 125/150 lb. flat face or 150 lb.
raised face (Cast Aluminum body option available with flat
face only).

94306 Materials of Construction

Body:

Cast Steel, Cast Aluminum, 304 Stainless Steel or 316
Stainless Steel

Hardware:

18-8 Stainless Steel Standard, 316 Stainless Steel

Tube Bank:

Aluminum with Aluminum Shell;
304 Stainless Steel with Steel Shell;
304 Stainless Steel with 304 Stainless Steel Shell;
316 Stainless Steel with 316 Stainless Steel Shell

Open Vent Outline Dimensions

Dimensions (Inches [mm])				
Valve Size	"B"	Diameter "D"	"E"	"H"
2 [50]	8 13/16 [224]	12 7/8 [327]	7 5/8 [194]	26 9/16 [675]
3 [75]	11 3/16 [284]	13 9/16 [345]	8 5/16 [211]	29 7/16 [748]
4 [100]	13 9/16 [345]	15 19/16 [405]	6 13/16 [173]	33 11/16 [856]
6 [150]	16 11/16 [424]	18 5/8 [473]	8 1/4 [210]	38 11/16 [983]
8 [200]	20 1/2 [521]	18 5/8 [473]	10 1/4 [260]	45 13/16 [1164]
10 [250]	24 11/16 [627]	25 9/16 [649]	12 1/4 [311]	57 1/16 [1449]
12 [300]	29 1/16 [738]	29 7/8 [759]	14 3/8 [365]	65 3/16 [1656]

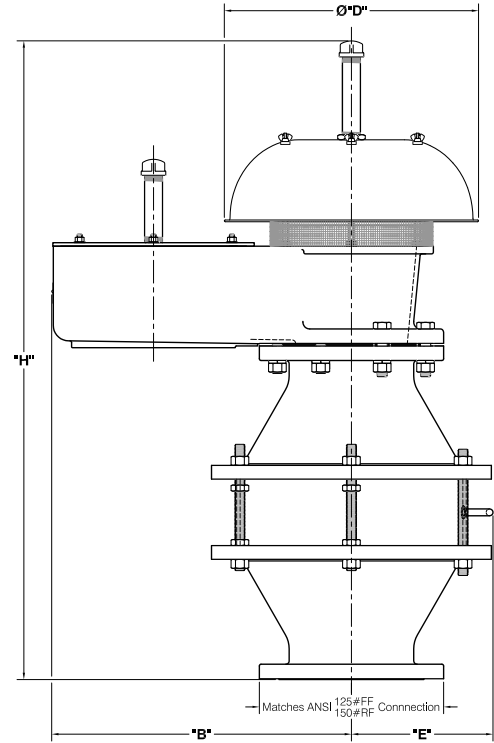

Closed Vent Outline Dimensions

Dimensions (Inches [mm])					
Valve Size Inlet x Outlet	"A"	"B"	"C"	"D"	"E"
2" x 2"	8 29/32 [226]	4 1/4 [108]	4 1/4 [108]	18 19/32 [468]	24 9/16 [624]
2" x 3"	[226]	[108]	4 1/4 [108]	18 7/16 [468]	24 9/16 [624]
3" x 3"	11 1/8 [283]	5 1/4 [133]	5 1/4 [133]	21 9/32 [540]	29 7/16 [748]
3" x 4"	[283]	[133]	5 1/4 [133]	21 5/8 [549]	29 7/16 [748]
4" x 4"	12 15/16 [328]	6 3/16 [157]	6 1/2 [165]	24 3/32 [633]	38 5/16 [973]
4" x 6"	[328]	[157]	5 15/16 [151]	24 1/16 [633]	34 1/4 [870]
6" x 6"	17 13/16 [452]	8 3/16 [208]	8 3/8 [213]	29 9/32 [743]	41 3/16 [1046]
6" x 8"	[452]	[208]	8 1/4 [210]	30 7/32 [767]	41 1/4 [1048]
8" x 8"	21 31/32 [558]	10 1/4 [260]	9 3/4 [248]	36 9/32 [920]	50 3/4 [1289]
8" x 10"	[558]	[260]	9 3/4 [248]	37 1/4 [946]	50 3/4 [1289]
10" x 10"	26 3/8 [670]	12 1/4 [311]	11 19/32 [294]	42 27/32 [1087]	59 3/16 [1503]
10" x 12"	[670]	[311]	11 19/32 [294]	43 23/32 [1110]	59 3/16 [1503]
12" x 12"	30 11/16 [780]	14 3/8 [365]	12 13/16 [325]	49 7/32 [1249]	67 [1702]
12" x 14"	[780]	[365]	12 13/16 [325]	49 3/4 [1264]	66 3/4 [1696]

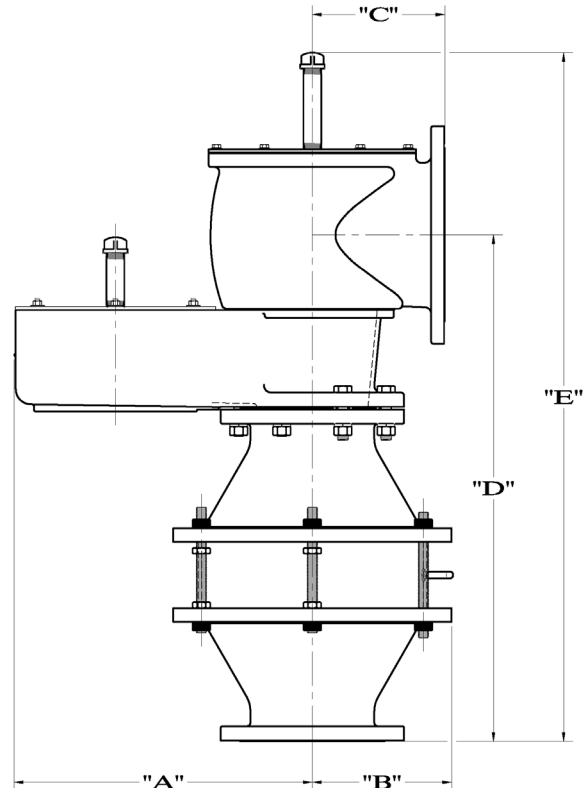

All designs subject to change. Certified dimensions and specifications available upon request.

97570 Ordering Guide

Model Number Selection

The model number will have a base number **97570** followed by 9 digit numbers. These digits will represent 8 sets of option tables.

97570 - AB - CD - EF - GH - I

Table AB - Size and Body Material

Option AB	Size	Type of Connection	Body Material
11	2"	NPT	Aluminum
12	2"	Flanged	Aluminum
21	2"	NPT	Alum Cryo Hood
22	2"	Flanged	Alum Cryo Hood
51	2"	NPT	Cast Steel
52	2"	Flanged	Cast Steel
71	2"	NPT	316 Stainless Steel
72	2"	Flanged	316 Stainless Steel
13	3"	NPT	Aluminum
14	3"	Flanged	Aluminum
23	3"	NPT	Alum Cryo Hood
24	3"	Flanged	Alum Cryo Hood
53	3"	NPT	Cast Steel
54	3"	Flanged	Cast Steel
73	3"	NPT	316 Stainless Steel
74	3"	Flanged	316 Stainless Steel
15	4"	Flanged	Aluminum
25	4"	Flanged	Alum Cryo Hood
55	4"	Flanged	Cast Steel
75	4"	Flanged	316 Stainless Steel
16	6"	Flanged	Aluminum
26	6"	Flanged	Alum Cryo Hood
56	6"	Flanged	Cast Steel
76	6"	Flanged	316 Stainless Steel
17	8"	Flanged	Aluminum
27	8"	Flanged	Alum Cryo Hood
57	8"	Flanged	Cast Steel
77	8"	Flanged	316 Stainless Steel
18	10"	Flanged	Aluminum
28	10"	Flanged	Alum Cryo Hood
58	10"	Flanged	Cast Steel
78	10"	Flanged	316 Stainless Steel
19	12"	Flanged	Aluminum
29	12"	Flanged	Alum Cryo Hood
59	12"	Flanged	Cast Steel
79	12"	Flanged	316 Stainless Steel

Table C - Flange Type

Option C	Description
0	FF ANSI 150 lb
1	*RF ANSI 150 lb
2	EN1092-1 16 FF
3	EN1092-1 16 RF*
4	JIS 10K FF
5	JIS 10K RF*

* RF not available in Aluminum

Table D - Vent Type

Option D	Description
1	Open Vent
2	Open Vent w/ Flame Snuffer
3	Closed, Standard Outlet > Inlet*
4	Pipe Away, P&V
6	Pipe Away, Same Size Inlet, Outlet, Seat
7	Open Vent with "All Weather" Coating
8	Open Vent with Flame Snuffer with "All Weather" Coating
9	Closed, Standard Outlet > Inlet with "All Weather" Coating
A	Pipe Away, Same Size Inlet, Outlet, Seat with "All Weather Coating
B	Open Vent with "All Weather" Coating with Insulation Jacket
C	Open Vent with Flame Snuffer with "All Weather" Coating & Insulation Jacket
D	Closed, Standard Outlet > Inlet with "All Weather" Coating & Insulation Jacket
E	Pipe Away, Same Size Inlet, Outlet, Seat with "All Weather Coating & Insulation Jacket

* Standard closed vent (outlet is one size larger than the inlet).
Ex. 2" Inlet X 3" Outlet, 6" Inlet X 8" Outlet.

NOTE: Option 6 replaced Option 5. Dimensions are not identical. Consult Factory if replacement valve is required.

Table E - Pallet / Seal Type

Option E	Pallet Type	Diaphragm
0	Standard	FEP
1	Expanda-Seal	FEP
4	Standard	FKM
5	Expanda-Seal	FKM
6	Standard	FPA
7	Expanda-Seal	FPA
8	Standard	NBR
9	Expanda-Seal	NBR
A	Std. Low Blow Down FEP	FEP
B	Std. Low Blow Down FKM	FKM
C	Std. Low Blow Down FPA	FPA
D	Std. Low Blow Down NBR	NBR

Table F - Pressure Range & Load Weight Material

Option F	Description	Material
1	**Standard Pressure and Vacuum Setting = 0.5 oz/in ²	Lead
2	Over 2.9 oz/sq. in. to Maximum Setting	Lead
3	> Standard to 2.9 oz/in ²	Lead
4	**Standard Pressure and Vacuum Setting = 0.5 oz/in ²	316 SS
5	Over 2.9 oz/in. ² to Maximum Setting	316 SS
6	> Standard to 2.9 oz/in. ²	316 SS
7	Incremental Weights Pressure Only 2.9 Oz. - 14 Oz. (5 in. W.C. - 24 in. W.C.)	Lead
8	Standard Incremental Weight Set Pressure Only 6" -16" W.C. in 1" Increments Including (1)-1/2 In. and (2)-1/4 In. W.C. Weights	Lead

**Expanda-Seal min. pressure setting: 1.5 oz/in.²

Table G - Seat & Pallet Material

Option G	Seat	Pallet
A	Standard*	Standard*
E	Stainless Steel	Standard*
F	Teflon Coated SS	Standard*
G	Standard*	316 Stainless Steel
K	Stainless Steel	316 Stainless Steel
L	Teflon Coated SS	316 Stainless Steel

*See Materials of Construction
Options G-L are applicable for Aluminum bodies only. 316 SS Pallet is standard on all other body options.

Temperature Limits

Diaphragm Material	Temperature Range
FEP	-65 F to 400 F
FKM	-15 F to 400 F
NBR	-40 F to 250 F
PFA	-65 F to 500 F

Table H - Cleaning & Trim

Option H	Cleaning	Trim
A	Normal	Standard
B	LOX	Standard
C	LIN	Standard
D	Normal	316 Stainless Steel
E	LOX	316 Stainless Steel
F	LIN	316 Stainless Steel

LOX = Liquid Oxygen

LIN = Liquid Nitrogen

Trim Includes Stem, Stem Guides, Side Guides, Nuts, Bolts and Screen.

NOTE: LOX/LIN cleaning for Cryogenic Breathers of aluminum construction includes degreasing before assembly only!

For LOX cleaning, use option 6 or 7 on Table E.

Table I - Flame Arrester, Tube Bank & Shell*

Option I	Tube Bank Material	Shell Material
1	Aluminum	Aluminum
6	304 Stainless Steel	Cast Steel
2	316 Stainless Steel	316 Stainless Steel
4	304 Stainless Steel	304 Stainless Steel

* Tie Rods and Nuts available in 18-8 SS Standard. If 316 SS required, please refer to Option H.