

## 95210 Clamping Manhole Cover

The Shand & Jurs 95210 Clamping Manhole Cover is designed as an economical solution that provides ready access to product storage tanks and anaerobic digester covers by means of an easily opened hinged cover.

The design of the 95210 employs a threaded clamping handle along with a flexible seal, affording a tight seal between the pallet and the corrosion resistant seat. This feature minimizes vapor leakage and provides for a watertight seal.

The design is also spark resistant when specified with bronze, brass or stainless steel clamping hardware. Specify ATEX option.

For tank gauging, access or examination, the entire hinged cover may be lifted open in a matter of seconds offering clear passage through the unobstructed opening.

All sizes have flat face, drilled flanges. An undrilled flange version and other special construction types are also available.

### Materials of Construction:

#### Base:

Aluminum, Steel, or Stainless Steel

#### Cover:

Aluminum, Steel, or Stainless Steel

#### Seal:

NBR (Nitrile-Butadiene) or CR = Chloroprene (Neoprene)

#### Clamping Hardware:

Stainless Steel, Steel, Brass or Bronze

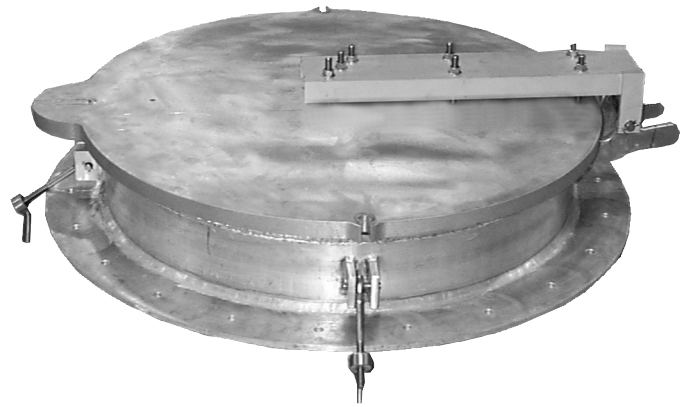

## Features

- Easy access to storage tanks and digester covers for maintenance and inspection
- 16", 18", 20", 24", 30", 36", 42" and 48" sizes
- ANSI, API, EN1092-1 and other connection types available
- Threaded clamping handle provides gas-tight and watertight seal
- Maximum working pressure of 1 psig
- Materials of construction include aluminum, steel & 316 Stainless Steel
- Steel, stainless steel, brass or bronze clamps

## Dimensions

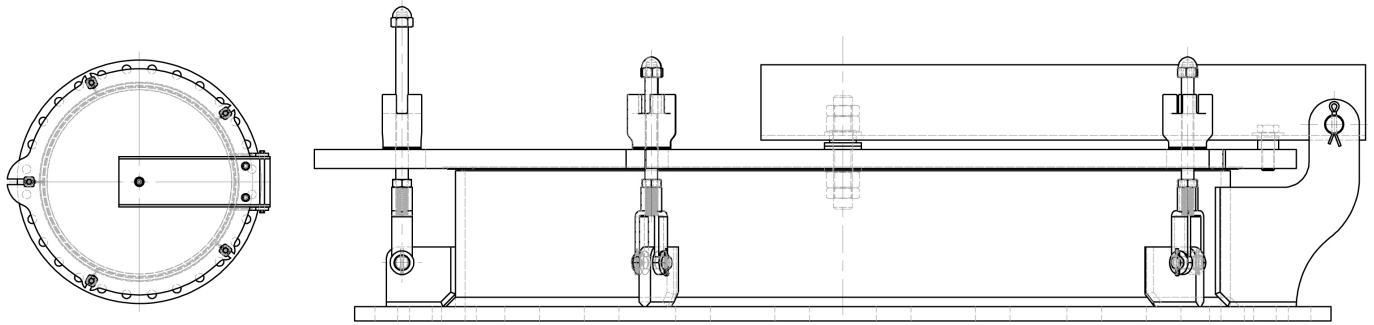

Top View (Steel Hardware)

95210 Manhole Cover (Steel Hardware)

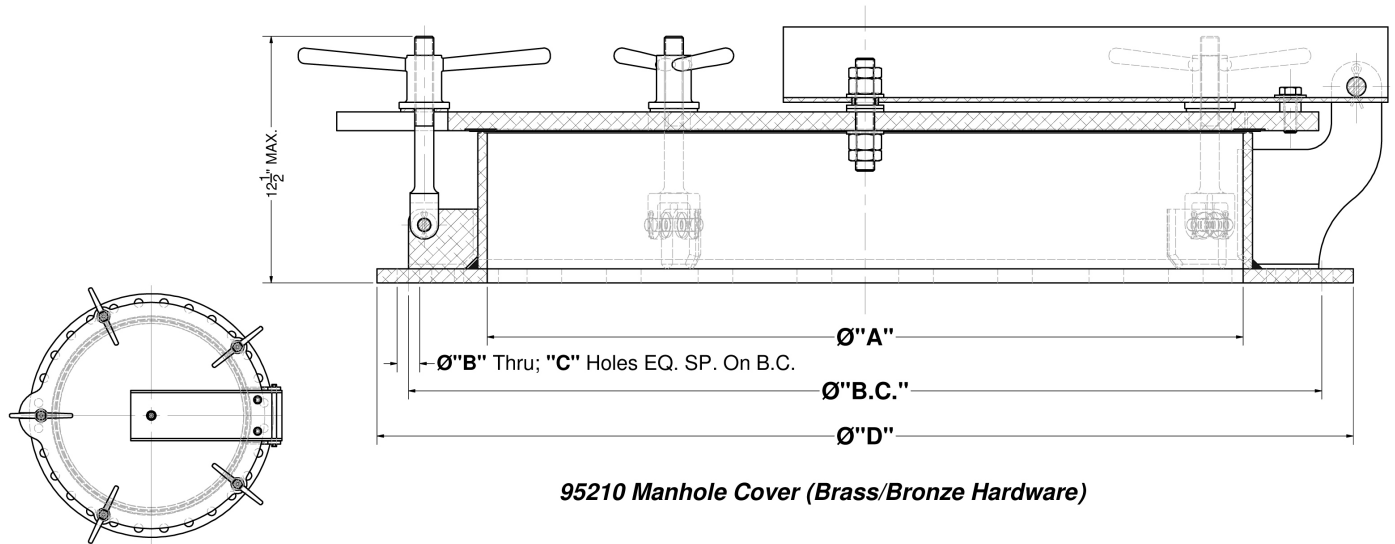

Top View (Brass/Bronze Hardware)

95210 Manhole Cover (Brass/Bronze Hardware)

Size	A	B	C Holes	B.C.	D	Connection
16"	16"	1 1/8"	16	21 1/4"	23 1/4"	ANSI 125/150 lbs. Flange Class
18"	18"	1 1/4"	16	22 3/4"	25"	
20"	20"	1 1/4"	20	25"	27 1/2"	
24"	24"	1 3/8"	20	29 1/2"	32"	
30"	30"	1 3/8"	28	36"	38 3/4"	
36"	35 1/4"	1 5/8"	32	42 3/4"	46"	
42"	42"	1 5/8"	36	49 1/2"	53"	
48"	47 1/4"	1 5/8"	44	56"	59 1/2"	
20"	20"	3/4"	16	23 1/2"	26"	API 650
24"	24"	3/4"	20	27 1/2"	30"	

All designs subject to change. Certified dimensions and specifications available upon request.

## 95210 Ordering Guide

### Model Number Selection

The model number will consist of a base number **95210** followed by 6 digit numbers. These digits will represent 5 option tables.

**95210 - AB - CD - EF**

### Ordering Information

Specify:

1. Model 95210 Clamping Manhole Cover
2. Size Required
3. Material
4. Connection Type
5. Type of Product Stored
6. For Other than Standard Materials, Specify as Required
7. Specify CE for Ordinary EU Locations use Table C, Option 1
8. ATEX Certification for II 1 G Ex h II B T1...T6 Ga EU Locations, use Table C, Option 2



### Table AB - Size & Material

Size (Inches)	Option AB Aluminum Base	Option AB Steel Base	Option AB 316S.S. Base
16	01	11	21
20	02	12	22
24	03	13	23
30	04	14	24
36	05	15	25
42	06	16	26
48	07	17	27
18	08	18	28

### Table C - CE or ATEX

Option C	Description
0	Standard
1	CE
2	ATEX Certified

### Table D - Drilling

Option D	Description
1	API 650*
2	ANSI (125/150 lb. FF)
3	Not Drilled (WELD)
4	Other**

\*Available in 20" & 24" sizes only, Consult Factory for other patterns.  
 \*\* Not available for ATEX Models

### Table E - Seal

Option E	Seal
0	CR
1	NBR

### Table F - Clamping Hardware

Option F	Clamping Hardware
0	Steel
1	Brass
2	Stainless Steel
3	Bronze