

94307 Horizontal End Of Line Flame Arrester

The Shand & Jurs 94307 Horizontal Flame Arrester is designed to provide a positive flame stop in gas piping systems. The 94307 not only provides exceptional protection against propagation of flame from external source, but also offers maximum flow capacity. It is specifically designed to prevent liquid accumulation in the tube bank assembly.

The tube bank design, consisting of a spiral wound crimped ribbon around a solid core, maximizes flow capacity with minimum pressure drop.

Standard construction includes cast aluminum, cast steel and 316 stainless steel body materials suitable for most environments. The tube bank is available in aluminum, 304 stainless steel and 316 stainless steel. The 94307 is gasketed for maximum of 10 psi static pressure standard.

Periodic inspection, maintenance and replacement of tube bank is as simple as removing tie-bolts and expanding the remaining jack screws. Once the body sections are expanded, the tube bank and shell are easily removed with the aid of a handle.

Available with flat face flanges for aluminum only or flat face raised or face flanges for cast steel, and stainless steel to match ANSI, EN1092-1, or JIS 10K connections.

For in-line deflagration arrester, see the Shand & Jurs 94407.

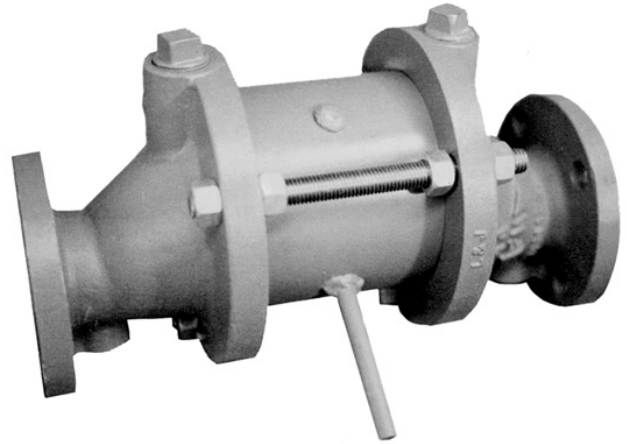

Features

- Unitized tube bank design
- Maximum protection and efficiency with minimum pressure drop
- Wide range of standard construction materials
- Easy inspection and maintenance, due to simple removal of tube bank
- Complete range of sizes from 2" through 12"
- NEC Group D gas applications
- Location within 10 pipe diameters of potential atmospheric ignition source

Specifications

Sizes:

2", 3", 4", 6", 8", 10" and 12"

Max. Static Pressure:

24.7 PSIA (10 PSIG)

Max. Pressure Operating:

15.7 PSIA (1.0 PSIG)

Flange Rating:

To match drilling of ANSI 125/150 lb. flat face or 150 lb. raised face (cast aluminum body option available with flat face only). EN1092-1 and JIS 10K options.

Gas Application:

NEC Group D Gas

Materials of Construction

Body:

Cast Steel, Cast Aluminum, or 316 Stainless Steel

Hardware:

18-8 Stainless Steel (Standard) or 316 Stainless Steel

Tube Bank:

Aluminum, 304 or 316 Stainless Steel

Gaskets:

Synthetic Composition

Outline Dimensions

Dimensions in Inches				
Vent Size	"A"	"B"	Diameter "D"	"F"
2"	14 1/2	8 5/32	6	5/8
3"	16	10 1/16	7 1/2	3/4
4"	20	12 3/16	9	15/16
6"	24 3/8	16 1/64	11	1
8"	32 1/8	20 7/8	13 1/2	1 1/8
10"	33 3/8	24 3/4	16	1 3/16
12"	34 3/8	29 5/16	19	1 1/4

Installation Note: Locate flame arrester within 10 pipe diameters of potential atmospheric ignition source.

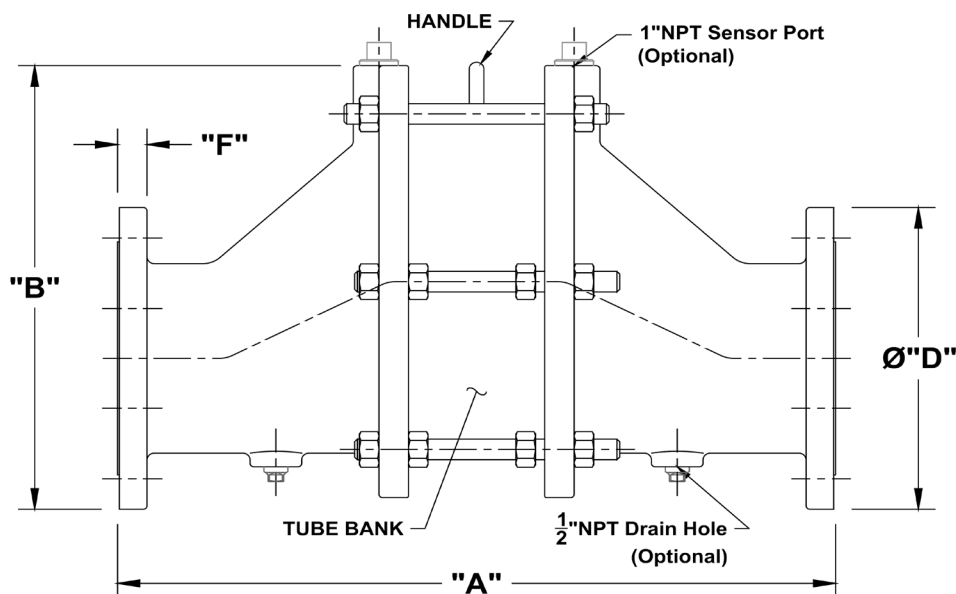

All designs subject to change. Certified dimensions and specifications available upon request.

94307 Ordering Guide

Model Number Selection

The model number will consist of a base number **94307** followed by 6 digit numbers. These digits will represent 2 option tables.

94307 - AB - CD - EF

Ordering Information

Specify:

1. Model 94307 Horizontal Flame Arrester
2. Size and Body Material

3. Tube Bank and Shell Material

4. Type of Flange Option

5. Special Materials or Coatings, If Required

Table AB - Size and Body

Table CD - Tube Bank and Shell

Option AB	Size (Inches)	Body Material	Option CD*	Tube Bank Material	Shell Material
12	2	Cast Aluminum	11 (12)	Aluminum	Aluminum
12	2	Cast Aluminum	66 (67)	304 Stainless Steel	Carbon Steel
12	2	Cast Aluminum	22 (23)	316 Stainless Steel	316 Stainless Steel
12	2	Cast Aluminum	44 (45)	304 Stainless Steel	304 Stainless Steel
14	3	Cast Aluminum	11 (12)	Aluminum	Aluminum
14	3	Cast Aluminum	66 (67)	304 Stainless Steel	Carbon Steel
14	3	Cast Aluminum	22 (23)	316 Stainless Steel	316 Stainless Steel
14	3	Cast Aluminum	44 (45)	304 Stainless Steel	304 Stainless Steel
15	4	Cast Aluminum	11 (12)	Aluminum	Aluminum
15	4	Cast Aluminum	66 (67)	304 Stainless Steel	Carbon Steel
15	4	Cast Aluminum	22 (23)	316 Stainless Steel	316 Stainless Steel
15	4	Cast Aluminum	44 (45)	304 Stainless Steel	304 Stainless Steel
16	6	Cast Aluminum	11 (12)	Aluminum	Aluminum
16	6	Cast Aluminum	66 (67)	304 Stainless Steel	Carbon Steel
16	6	Cast Aluminum	22 (23)	316 Stainless Steel	316 Stainless Steel
16	6	Cast Aluminum	44 (45)	304 Stainless Steel	304 Stainless Steel
17	8	Cast Aluminum	11 (12)	Aluminum	Aluminum
17	8	Cast Aluminum	66 (67)	304 Stainless Steel	Carbon Steel
17	8	Cast Aluminum	22 (23)	316 Stainless Steel	316 Stainless Steel
17	8	Cast Aluminum	44 (45)	304 Stainless Steel	304 Stainless Steel
18	10	Cast Aluminum	11 (12)	Aluminum	Aluminum
18	10	Cast Aluminum	66 (67)	304 Stainless Steel	Carbon Steel
18	10	Cast Aluminum	22 (23)	316 Stainless Steel	316 Stainless Steel
18	10	Cast Aluminum	44 (45)	304 Stainless Steel	304 Stainless Steel
19	12	Cast Aluminum	11 (12)	Aluminum	Aluminum
19	12	Cast Aluminum	66 (67)	304 Stainless Steel	Carbon Steel
19	12	Cast Aluminum	22 (23)	316 Stainless Steel	316 Stainless Steel
19	12	Cast Aluminum	44 (45)	304 Stainless Steel	304 Stainless Steel
52	2	Cast Steel	66 (67)	304 Stainless Steel	Carbon Steel

HARDWARE: 18-8 SS Standard; Use CD (XX) option for 316 SS; 316 SS Standard for 316 SS Body

Table AB - Size and Body

Table CD - Tube Bank and Shell

Option AB	Size (Inches)	Body Material	Option CD*	Tube Bank Material	Shell Material
52	2	Cast Steel	22 (23)	316 Stainless Steel	316 Stainless Steel
52	2	Cast Steel	44 (45)	304 Stainless Steel	304 Stainless Steel
42	2	Cast 316 Stainless Steel	22	316 Stainless Steel	316 Stainless Steel
54	3	Cast Steel	66 (67)	304 Stainless Steel	Carbon Steel
54	3	Cast Steel	22 (23)	316 Stainless Steel	316 Stainless Steel
54	3	Cast Steel	44 (45)	304 Stainless Steel	304 Stainless Steel
44	3	Cast 316 Stainless Steel	22	316 Stainless Steel	316 Stainless Steel
55	4	Cast Steel	66 (67)	304 Stainless Steel	Carbon Steel
55	4	Cast Steel	22 (23)	316 Stainless Steel	316 Stainless Steel
55	4	Cast Steel	44 (45)	304 Stainless Steel	304 Stainless Steel
45	4	Cast 316 Stainless Steel	22	316 Stainless Steel	316 Stainless Steel
56	6	Cast Steel	66 (67)	304 Stainless Steel	Carbon Steel
56	6	Cast Steel	22 (23)	316 Stainless Steel	316 Stainless Steel
56	6	Cast Steel	44 (45)	304 Stainless Steel	304 Stainless Steel
46	6	Cast 316 Stainless Steel	22	316 Stainless Steel	316 Stainless Steel
57	8	Cast Steel	66 (67)	304 Stainless Steel	Carbon Steel
57	8	Cast Steel	22 (23)	316 Stainless Steel	316 Stainless Steel
57	8	Cast Steel	44 (45)	304 Stainless Steel	304 Stainless Steel
47	8	Cast 316 Stainless Steel	22	316 Stainless Steel	316 Stainless Steel
58	10	Cast Steel	66 (67)	304 Stainless Steel	Carbon Steel
58	10	Cast Steel	22 (23)	316 Stainless Steel	316 Stainless Steel
58	10	Cast Steel	44 (45)	304 Stainless Steel	304 Stainless Steel
48	10	Cast 316 Stainless Steel	22	316 Stainless Steel	316 Stainless Steel
59	12	Cast Steel	66 (67)	304 Stainless Steel	Carbon Steel
59	12	Cast Steel	22 (23)	316 Stainless Steel	316 Stainless Steel
59	12	Cast Steel	44 (45)	304 Stainless Steel	304 Stainless Steel
49	12	Cast 316 Stainless Steel	22	316 Stainless Steel	316 Stainless Steel

HARDWARE: 18-8 SS Standard; Use CD (XX) option for 316 SS; 316 SS Standard for 316 SS Body

Table EF - Flange Type and Drain Plugs

Flange Style	No Drain Plugs Option EF	With Drain Plugs Option EF
ANSI 125/150lb. FF	77	71
ANSI 125/150lb. RF*	87	81
EN1092-1 PN16 FF	27	21
EN1092-1 PN16 RF*	37	31
JIS 10K FF	47	41
JIS 10K RF*	57	51

Note: Raised faced flanges with smooth finish are standard.
For optional serrated raised faced flanges, consult factory.

*Raised Face Flanges not available with Aluminum bodies.

Tube Banks Only

Parts Number	Size (Inches)	Tube Bank Material	Shell Material	Shipping Weight (lbs.)
9430-10150	2	Aluminum	Aluminum	9
091211	2	304 Stainless Steel	Carbon Steel	22
9430-11120	2	304 Stainless Steel	304 Stainless Steel	25
9430-11110	2	316 Stainless Steel	316 Stainless Steel	25
9430-10151	3	Aluminum	Aluminum	14
091212	3	304 Stainless Steel	Carbon Steel	30
9430-11121	3	304 Stainless Steel	304 Stainless Steel	35
9430-11111	3	316 Stainless Steel	316 Stainless Steel	35
9430-10152	4	Aluminum	Aluminum	20
091213	4	304 Stainless Steel	Carbon Steel	55
9430-11122	4	304 Stainless Steel	304 Stainless Steel	60
9430-11112	4	316 Stainless Steel	316 Stainless Steel	60
9430-10153	6	Aluminum	Aluminum	35
9430-11070	6	304 Stainless Steel	Carbon Steel	90
9430-11123	6	304 Stainless Steel	304 Stainless Steel	100
9430-11113	6	316 Stainless Steel	316 Stainless Steel	100
9430-10154	8	Aluminum	Aluminum	55
9430-11071	8	304 Stainless Steel	Carbon Steel	145
9430-11124	8	304 Stainless Steel	304 Stainless Steel	160
9430-11114	8	316 Stainless Steel	316 Stainless Steel	160
9430-10155	10	Aluminum	Aluminum	85
9430-11072	10	304 Stainless Steel	Carbon Steel	225
9430-11125	10	304 Stainless Steel	304 Stainless Steel	240
9430-11115	10	316 Stainless Steel	316 Stainless Steel	240
9430-10156	12	Aluminum	Aluminum	120
9430-11073	12	304 Stainless Steel	Carbon Steel	310
9430-11126	12	304 Stainless Steel	304 Stainless Steel	320
9430-11116	12	316 Stainless Steel	316 Stainless Steel	320

L&J Technologies or any of its subsidiaries assume no responsibility and shall not be liable for any damage, injury or death caused by the mis-application or improper installation of the products that it provides. Installation shall be per manufacturer's instructions in accordance to any applicable local, state or federal regulations. It is the responsibility of the purchaser to ensure these guidelines are followed and that the products are applied properly.