

94261 Vapor Recovery Regulator

The Shand & Jurs 94261 Vapor Recovery Regulator is a float-operated pressure regulator utilizing a weight balanced float to establish a set point. This highly accurate and extremely sensitive regulator is used to maintain close pressure control of low pressure tanks and meets requirements for vapor recovery.

The primary purpose of this vent is to conserve vapor loss before atmospheric venting or to provide a closed venting system. It has the capacity of providing simple adjustment of set points by adding or removing weights.

The 94261 is a totally self-actuated regulator requiring no outside source of energy for its operation. A straight forward mechanical design using a minimum of moving parts provides for long service life with minimum maintenance.

In Figure A, when positive pressure above set point exists in the tank, it allows gas vapors to be moved. At this point, the gas pressure in space with atmosphere pressure in S1, will raise the valve assembly and permit vapor flow from the tank to a recovery system.

In Figure B, when negative pressure (vacuum condition) below set point exists in the tank, it allows gas vapor to flow into the tank. Negative pressure from the tank vapor space enters the control line in the regulator space S2, with atmosphere pressure in S1, will lift the valve assembly allowing vapor flow into the tank.

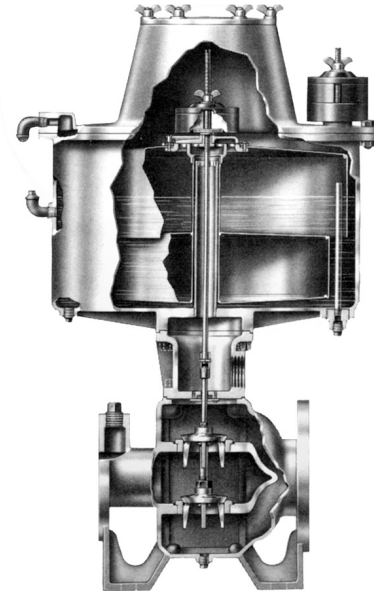

Features

- Operates within 1/10'' W.C. from operating ranges of 1/10'' W.C. to 2'' W.C.
- Reduced number of moving parts maximizes service life
- No external power source required
- Can provide four types of service:
 - (1) pressure increase
 - (2) vacuum increase
 - (3) pressure decrease
 - (4) vacuum decrease

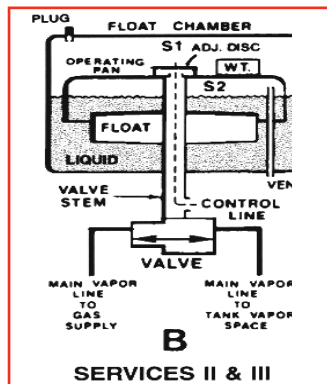
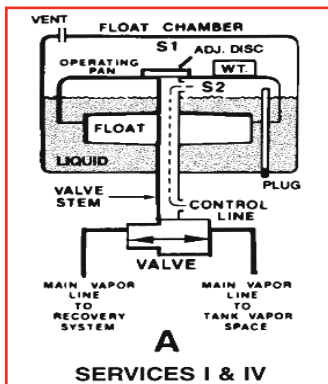

Installation

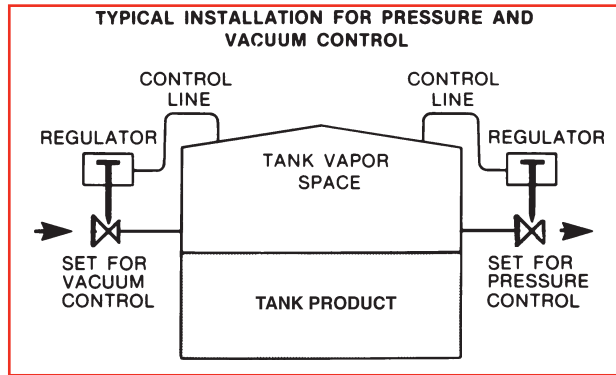

Materials of Construction

Steel

Dimensions

Size	Table of Dimensions									Weight in lbs.
	"A"	"B"	"C"	"D"	"E"	"F"	"G"	"H"	"J"	
2"	2	3	10 ¾	23	11	5	8	2 ¼	6 ¾	177
3"	3	4	11 ½	23	12	6	8 ½	3	6 ¾	185
4"	4	6	12 ¾	23	15	8	10	4	6 ¾	230
6"	6	8	17 ¾	23	18	10 ¼	13 ½	4 ½	10 ¼	309

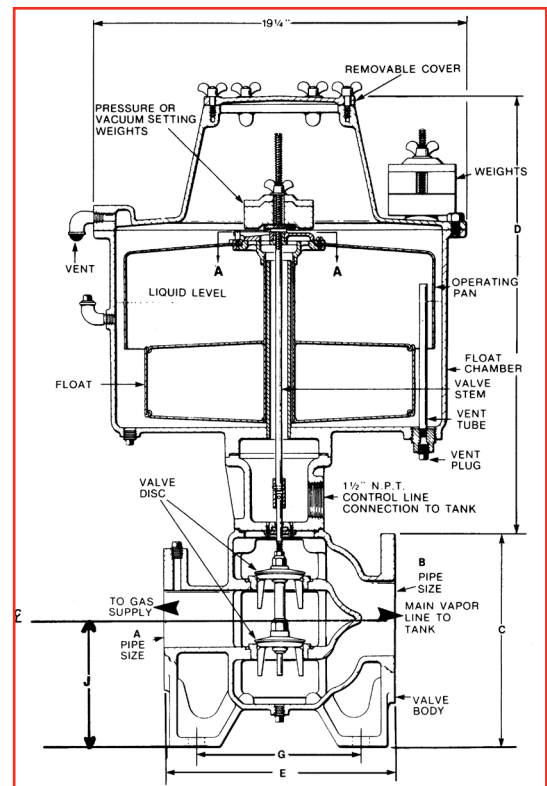
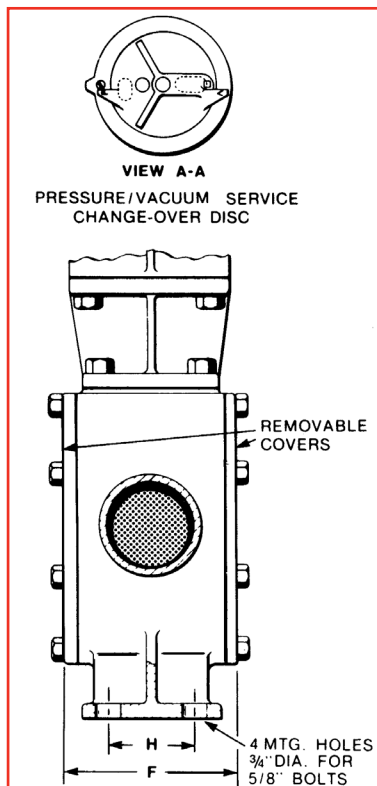

All designs subject to change. Certified dimensions and specifications available upon request.

94261 Ordering Guide

Model Number Selection

The model number will consist of a base number **94261** followed by 2 digit numbers. These digits will represent 1 option table.

94261 - AB

Ordering Information

Specify:

1. Model 94261 Vapor Recovery Regulator
2. Size
3. Body Material
4. Flange Type
5. Type of Service

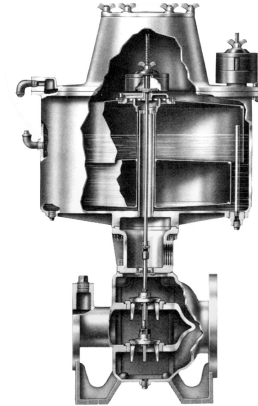

Table AB - Size (125 lb Flat Face)*

Option AB	Description	Weight (lbs.)
11	2" x 3" Steel	215
12	3" x 4" Steel	230
13	4" x 6" Steel	285
14	6" x 8" Steel	-----

* Other Flange sizes available

Capacity Curves

