

evo 2600 Radar Level Gauge

The evo 2600 Radar Level Gauge is the latest product in L&J Engineering's new evolution series of radar level gauges which are leading the industry with innovative new features and benefits not found in other products. The evo 2600 uses L&J's latest and most technologically advanced radar technology to deliver 3mm Accuracy in a wide variety of applications at a competitive cost. The evo 2600 uses FMCW (Frequency Modulated Continuous Wave) technology operating in the 26GHz frequency band to ensure that it delivers both accuracy and reliability in a wide variety of level gauging applications. This technology is designed, tested and manufactured in the USA, ensuring a high quality and reliable product.

e.WAVE Display

An all new evolutionary feature of the evo 2600 is the e.WAVE graphical LCD display. In case of special applications or circumstances, the e.WAVE display provides you with a graphical profile of your tank to ensure there are no unforeseen obstructions or intrusions in your level gauging applications. The e.WAVE will allow you to fine tune the radar unit to cancel out any obstructions or other disturbances in the tank. This is all done with the MCG 2150 Remote Calibrator. Never before has it been this easy to fine tune a radar gauge to operate in your specific environment. The e.WAVE display also provides you with a vast array of information, including, but not limited to: level, temperature, discrete status, and a magnitude of diagnostics. There is also an optional ground level display which allows you to program and setup the radar gauge at the side of the tank.

e.CAL Intuitive Setup Wizard

The evo 2600 uses L&J's e.CAL Intuitive Setup Wizard to assure easy programming and setup of your radar gauge in minutes. Once you enter programming mode with your MCG 2150 Remote Calibrator, the evo 2600's e.CAL mode is the first option displayed. Once entering e.CAL, you will be asked to enter 5 values: units of measure, Datum level, max fill level, min fill level, and seed level. The radar will then begin to profile the tank and you will be up and gauging in less than 5 minutes!



Features

- +/- 3mm Accuracy Standard
- 4-20ma Loop Powered
- 26 GHz Frequency
- FMCW Technology
- e.WAVE Display
- e.CAL Intuitive Setup Wizard
- Lightweight

Applications

Liquid level gauging of virtually any corrosive, contaminated or viscous product including;

oil	chemicals	gasoline
petrochemical	molten sulfur	pharmaceuticals
limestone rock	polyethylene	titanium dioxide
paraffin	latex	powder and bulk

Specifications:

Measuring Range:

0-65 feet standard.

Accuracy:

+/- 3 mm (+/- 0.12 in)

Radar Frequency:

26GHz FMCW Technology

Electronics Temperature:

-40° F to 150° F (-40° C to 66° C)

Process Temperature:

-148° F to 320° F (-100° C to 160° C)

Digital Communications:

L&J Tankway

Other Protocols Available (See Ordering Guide)

Temperature Option:

Spot Temperature (3-Wire RTD)

Local Display:

e.WAVE Graphical LCD Display

Power Supply:

24V Loop Power, 24VDC, 48VDC

Power Consumption:

Loop Power 36 mW

Process Pressure:

150PSIG

Process Connection:

2" NPT

Weight:

2 lbs.

Safety Approvals:

FM/FMC: Class I, Div. 1, Groups B, C, D;
Class II, III, Div. 1, Groups E, F, G
(Ta = -40°C to 66°C)

ATEX II 1/2 G Ex db IIB T6 Ga/Gb (Ta = -40°C to 66°C)
II 2 D Ex tb IIIC T85°C Db (Ta = -40°C to 66°C)

IECEx Ex db IIB T6 Ga/Gb (Ta = -40°C to 66°C)
Ex tb IIIC T85°C Db (Ta = -40°C to 66°C)

Dimensions

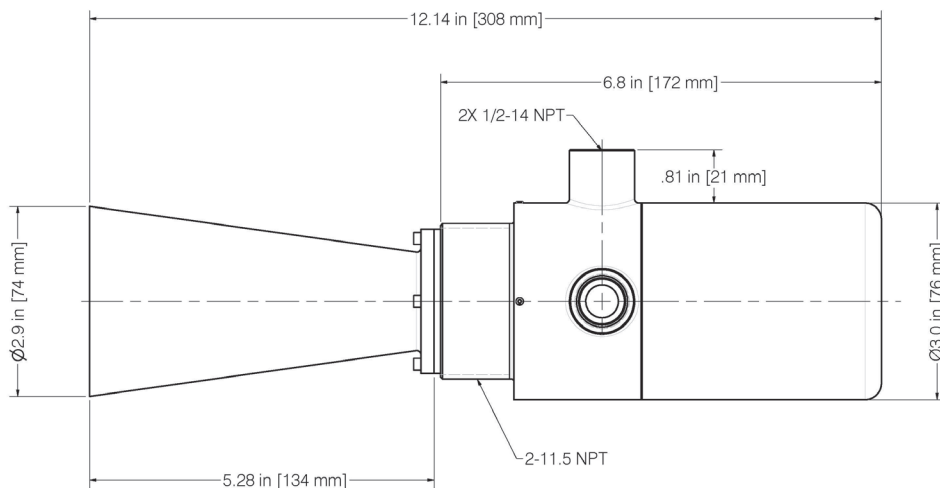

All designs subject to change. Certified dimensions and specifications available upon request.

Accessories



MCG 2150
Handheld Infrared Calibrator



MCG 1350M
Ground Level Display

evo 2600 Radar Level Gauge Ordering Guide

evo 2600 Radar Level Gauge

MCG 2150 Remote Calibrator

(One Required)

Model Number Selection:

The model number will consist of a base number **2600** followed by 10 digits. These digits will represent 10 sets of option tables:

evo 2600 - A - B - C - D - E - F - G - H - I

A - Approval	
1	FM / FMC
2	CSA
3	ATEX/ IECEx

B - Housing Material	
1	Aluminum

C - Antenna Options	
0	No Antenna
2	3" Conical Horn Antenna 316SS
3	4" Conical Horn Antenna 316SS
4	6" Conical Horn Antenna 316SS
5	8" Conical Horn Antenna 316SS
6	Parabolic Antenna
7	Float and Tape Gauge Replacement*
8	6" Hinged Hatch Mount Antenna

* evo 2600SW Required

D - Process Connection	
0	No Flange, 2" NPT Connection
1	2" 150# RF ANSI 316SS
2	3" 150# RF ANSI 316SS
3	4" 150# RF ANSI 316SS
4	6" 150# RF ANSI 316SS
5	8" 150# RF ANSI 316SS
6	2" 300# RF ANSI 316SS
7	3" 300# RF ANSI 316SS
8	4" 300# RF ANSI 316SS
9	6" 300# RF ANSI 316SS
A	8" 300# RF ANSI 316SS
B	1.5" NPT Connection*
C	3" NPT Connection*
D	4" NPT Connection*

* evo 2600SW Required

* Must select Table F, Option 1, and Table G, Option 1.



E - Digital Communication Protocol	
0	None
1	L&J Tankway
2	GPE 31422, 31423
3	Varec 4-Wire (1800, 1900)
4	Modbus on L&J Tankway
5	Modbus on RS 485 (2-Wire)
6	ENRAF
7	Fieldbus
A	Ti-Way
B	HART*
C	Saab TRL/2
D	Profibus DP
E	RGL / NMC
F	WirelessHART

F - Analog Output	
0	None
1	Single 4-20mA Output*

* Must select Table E, Option 0 or B, and Table G, Option 1.

G - Power*	
1	24 VDC Loop Powered
2	24-48 VDC

*For other Input Voltages External adapter required.
Consult Factory for more information.

H - Temperature Inputs	
0	No Temperature
1	Single Spot Temperature*

* Spot Temperature Ready. RTD Probe must be ordered separately.

I - Ground Level Display*	
1	Ground Level Display Compatibility

* Requires MCG 1350M Ground level Display.

