

## 94270 Vapor Guard Tank Blanketing Valve

### What is Tank Blanketing?

Gas blanketing systems are used to prevent the escape of liquid vapors into the atmosphere or to prevent moisture from entering a tank and contaminating its contents. A tank blanketing valve maintains an inert gas blanket (usually nitrogen or carbon-dioxide) in the vapor space of a pressure-tight liquid storage vessel. This process is accomplished by utilizing a steady high-pressure gas source and the Shand & Jurs 94270 "VAPOR GUARD" so that flow is limited to a constant value when the tank pressure drops below the set point. The valve limits the minimum pressure of the gas blanketing to cope with outdoor temperature reductions or pump outs without in-breathing air. When pressure inside the vessel exceeds the valves set point the main valve shuts off. If pressure increases due to outdoor thermal heating, or product pump-ins, the separate breather valve opens and relieves the excess pressure. One advantage of using the Shand & Jurs "VAPOR-GUARD" is that only one valve is needed to maintain precise blanketing regulation while conventional recovery systems require several regulators to achieve the same results.

### How does it work?

The Shand & Jurs 94270's compact design allows the valve to be mounted directly on the tank which in turn not only reduces the number of necessary connections, but also possible leak points. Models are available with female thread connections and welded or threaded-on flanges. The 94270 has a balanced, piston operated, main valve so that the set point pressure is virtually unchanged at any given inlet pressure within the specified operating range. The "VAPOR GUARD" has a modulating type action valve that opens and closes automatically, maintaining a closely controlled blanket pressure and gas flow. The modulating action simplifies the valve design thus increasing reliability and reducing maintenance costs. The "VAPOR GUARD" operates in the closed position whenever the tank pressure is satisfied or exceeds the set pressure. Whenever the sensed pressure decreases, the set pressure spring and diaphragm assembly causes a downward force such that the main valve will open proportionately to control pressure and limit capacity.

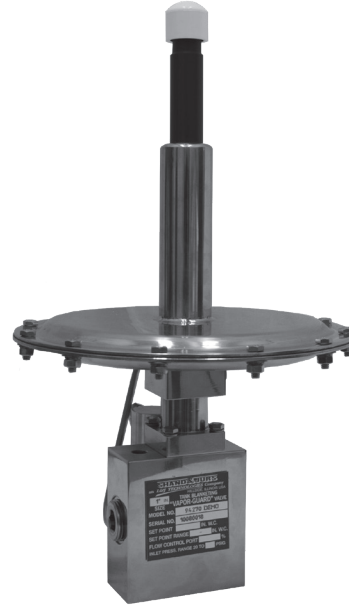

### Features

- Lower maintenance cost due to fewer parts
- Compact/light weight design occupies less space with less stress to tank
- Eliminates the effects of valve leakage and waste of blanketing gas
- One valve system
- Horizontal or vertical mounting
- Set pressure is the only adjustment
- 316 SS trim and seats standard
- Pilot filter standard on 1" and 2" model
- Optional filter, check valve, pressure gauge

### **Flow Disc Control Port**

Each valve is fitted with a percentage flow control port to meet specific calculated gas blanketing flow requirements based on a steady gas pressure supply. Referral to a flow capacity chart is necessary to size each valve for a particular gas blanketing system. Standard flow control ports are available in five options: 10% 25%, 50%, 75% and 100% of the published flow charts to reduce the flow rate to optimum operating conditions. On 1/2" model, 200% and 150% flow control ports are available to increase flow rate at inlet pressures up to 100 psig.

### **Set Pressures:**

Set pressures are available from 0.50" WC to 15.0 psig.

### **Inlet Pressure:**

1/2" size: 20-200 PSIG  
1" Size: 30-200 PSIG  
2" size: 30-100PSIG

\*The Inlet Pressure should be specified when ordering the valve.

## **94270 Theory of Operation**

The latest innovations in valve design include a balanced, piston operated, main valve so that the set point is virtually unchanged at any given inlet pressure within the specified operating range. This type of valve is not a pressure reducing regulator, but rather a modulating valve that automatically opens and closes, as needed, to maintain a closely controlled blanket pressure. Modulating action is preferred over pressure regulation because of the simplified valve design and its inherent reliability and maintainability. Typical operation calls for the valve to operate in the closed position whenever the tank pressure is satisfied or when it exceeds the set pressure. As the sensed pressure decreases, the set pressure spring and diaphragm assembly causes a downward force such that the main valve will open proportionately to control pressure and limit flow capacity.

Should the pressure in the pilot chamber drop to a point where it can no longer hold against the pilot set pressure, the pilot spindle moves downward, causing the pilot to unseat. This creates a flow from the pilot inlet, through a small orifice, out the pilot discharge tube and into the tank. The pressure above the main valve is then reduced by a pressure drop downstream. When sufficient pressure drop is achieved, the supply pressure will push open the piston and allow the blanketing gas to enter the tank. When the blanketing gas brings the tank pressure up to the set point, the pilot flow then stops and full supply pressure builds above the piston to close the main valve.

### **Sizing A Vapor Guard**

There are two criteria for sizing the valve for tank blanketing: (A) blanketing gas replacement for liquid loss during pump out and (B) the condensation/contraction of tank vapors during atmospheric thermal cooling. Required amount of blanketing gas and correct size of valve must be determined on the basis that both conditions could occur simultaneously. The maximum flow rate through the valve will determine its size.

### **To Size A Valve**

1. Determine the gas flow rate due to pump out (Table A).
2. Determine the gas flow rate due to atmospheric thermal cooling. (Table B) See excerpt from API 2000.

### **Excerpt from API 2000 (Annex A)**

For tanks with a capacity of 20,000 bbl or more, the requirements for the vacuum condition are very close to the theoretically computed value of 2 cubic feet of air per hour per square foot of total shell and roof area. For tanks with a capacity of less than 20,000 bbl, the requirements for the vacuum condition have been based on 1 cubic foot of free air per hour for each barrel of tank capacity. This is substantially equivalent to a mean rate if vapor space temperature change is 100°F per hour in the vapor space.

3. Add the requirements of 1 & 2 and select the valve size based on the blanketing gas capacity.
4. Check table C or D for the gas flow rate at 100% to determine the smallest valve size that will approximately meet the flow rate at the corresponding supply pressure. See Table E.

If further flow rate reduction is required, select the 75%, 50% 25% or 10% flow port option that will adequately cover all operating contingencies. On 1/2" model, 200% and 150% flow control ports are available to increase flow rates. This includes the capacity sizing of the breather valve in the unlikely event of a failed open main valve at maximum inlet pressure.

**NOTE:** In order to ensure reliable operation, a filter is required within 6" of valve inlet. This filter must be sized for inlet requirements determined above.

**Table B**

Vessel (Barrels)	Capacity (Gallons)	*In Breathing SCFH Air Required
60	2,000	60
100	4,200	100
500	21,000	500
1,000	42,000	1,000
2,000	84,000	2,000
3,000	126,000	3,000
4,000	168,000	4,000
5,000	210,000	5,000
10,000	420,000	10,000
15,000	630,000	15,000
20,000	840,000	20,000
25,000	1,050,000	24,000
30,000	----	28,000
35,000	----	31,000
40,000	----	34,000
45,000	----	37,000
50,000	----	40,000
60,000	----	44,000
70,000	----	48,000
80,000	----	52,000
90,000	----	56,000
100,000	----	60,000
120,000	----	68,000
140,000	----	75,000
160,000	----	82,000
180,000	----	90,000

**Table C**

Capacities Based on 14.7 PSIA Outlet Pressure & 60°F						
Inlet Pres. PSIG	Flow Capacity - SCFH @ 60°F Gas Temp. - 1/2" Size					
	Ext. & Dip Tube Sense - 100% Flow Control			Internal Sense - 25% Flow Control		
	Air	Nitrogen	0.6G Nat Gas	Air	Nitrogen	0.6G Nat Gas
20	450	457	574	112	114	143
30	610	620	779	153	155	195
40	750	762	957	188	191	240
50	870	884	1,110	218	221	278
60	1,030	1,046	1,315	258	262	329
70	1,180	1,199	1,506	295	300	377
80	1,310	1,331	1,672	328	333	419
90	1,460	1,483	1,864	365	371	466
100	1,600	1,625	2,042	400	406	511
110	1,750	1,777	2,334	438	445	559
120	1,880	1,909	2,400	470	477	600
130	2,020	2,052	2,578	505	513	645
140	2,160	2,194	2,757	540	548	689
150	2,300	2,336	2,936	575	584	734
160	2,430	2,468	3,102	608	618	776
170	2,570	2,610	3,280	643	653	821
180	2,700	2,742	3,446	675	686	862
190	2,840	2,885	3,625	710	721	906
200	2,980	3,027	3,804	745	757	951

NAT = Natural Gas

**Table D**

Capacities Based on 14.7 PSIA						
Flow Capacity - SCFH @ 60°F Gas Temp.						
Inlet Pres. PSIG	1" Size			2" Size		
	100% Flow Control Ext. & Dip Tube Sense					
	Air	Nitrogen	0.6G Nat Gas	Air	Nitrogen	0.6G Nat Gas
30	17,100	17,368	21,826	67,000	68,051	85,519
40	20,500	20,821	26,166	83,000	84,301	105,941
50	24,500	24,884	31,272	99,000	100,552	126,364
60	28,500	28,947	36,377	115,000	116,803	146,786
70	32,500	33,010	41,483	130,000	132,038	165,932
80	36,600	37,174	46,716	146,000	148,289	186,354
90	40,500	41,135	51,694	161,000	163,524	205,500
100	44,500	45,198	56,800	177,000	179,775	225,923
110	48,500	49,260	61,905			
120	52,500	53,323	67,011			
130	56,000	56,878	71,478			
140	60,000	60,941	76,584			
150	62,700	63,683	80,030			
160	67,000	68,050	85,519			
170	71,000	72,113	90,624			
180	74,000	75,160	94,454			
190	78,000	79,223	99,559			
200	82,000	83,286	104,664			

\* Referenced from API 2000 6<sup>th</sup> Edition Annex A. Refer to API 2000/ISO 28300 for appropriate requirements.

**Table A**

Multiply Max. Pump Out Rate In	B	To Obtain
U.S. Gallons per Minute	8.021	SCFH Air Required
U.S. Gallons per Hour	0.1337	SCFH Air Required
Barrels per Hour	5.615	SCFH Air Required
Barrels per Day	0.2340	SCFH Air Required

**Table E**

Standard Flow Coefficients			
Sizes	To Obtain Reduced Flow of	Multiply Table C or D Figures by	To Obtain
All	75%	.75	SCFH
All	50%	.50	SCFH
All	25%	.25	SCFH
All	10%	.10	SCFH
1/2"	200%	2.0	SCFH
1/2"	150%	1.5	SCFH

**Table F**

Correction Factor from 60°F Temp Base			
Actual Temp	Correction Factor	Actual Temp	Correction Factor
-20	1.087	100	.9636
0	1.063	120	.9469
20	1.041	150	.9233
40	1.020	200	.8876
60	1.000	250	.856
80	.9813	----	----

(Apply to Tables C & D)

## Specifications

### Body

304 Stainless Steel or 316 Stainless Steel

### Diaphragm Housing

Painted Carbon Steel or 316 Stainless Steel

### Trim & Seats

316 Stainless Steel

### Diaphragm

EDPM (Ethylene Propylene Diene Monomer), FEP (Fluorinated Ethylene Propylene), FKM (Fluoroelastomer), NBR (Nitrile-Butadiene)

### Seals:

EDPM (Ethylene Propylene Diene Monomer), FKM (Fluoroelastomer), FFKM (Perfluoroelastomer), NBR (Nitrile-Butadiene)

### Temperature:

-40° F to 250° F (NBR and EPDM)  
+20° F to 350° F (FKM and FFKM)

### Set Pressure (Opening):

1/2" wc to 15.0 psig

### Minimum Inlet Pressure:

1/2" Size: 20 PSIG  
1" & 2" Size: 30 PSIG

### Maximum Inlet Pressure:

2" Size: 100 psig - 100% Flow Port  
1" Size: 200 psig - 100% Flow Port  
1/2" Size: 200 psig - 100% Flow Port  
125 psig - 150% Flow Port  
100 psig - 200% Flow Port

### Maximum Pressure at Sense Port:

3.0 psig (20.0 psig for set point > 3.0 psig)

### Connections:

FNPT Thread  
Flanged ANSI 150 lb RF  
Flanged ANSI 150 lb Weld Neck RF  
Flanged ANSI 300 lb Weld Neck RF  
Flanged EN1092-1 PN16 RF

\*Other materials of construction available upon request.

## Dimensions

Size	Dimensions in Inches									
	"A"	"B"	"C"	"D"	"E"	"F"	"G"	"H"	"I"	"J"
1/2"	2 15/16	7/8	1 7/16	14 13/16	5 3/4	3 5/8	17 9/16	2 15/32	7 7/8	1 19/32
1"	3 1/8	7/8	1 3/8	19 15/32	5 5/16	3 1/16*	21 21/32*	2 3/8	8 3/8**	1 1/2
2"	N/A	1 3/8	2 1/2	20 15/32	6 7/8	3 3/4	22 27/32	4 3/16	11 1/4	2 13/16

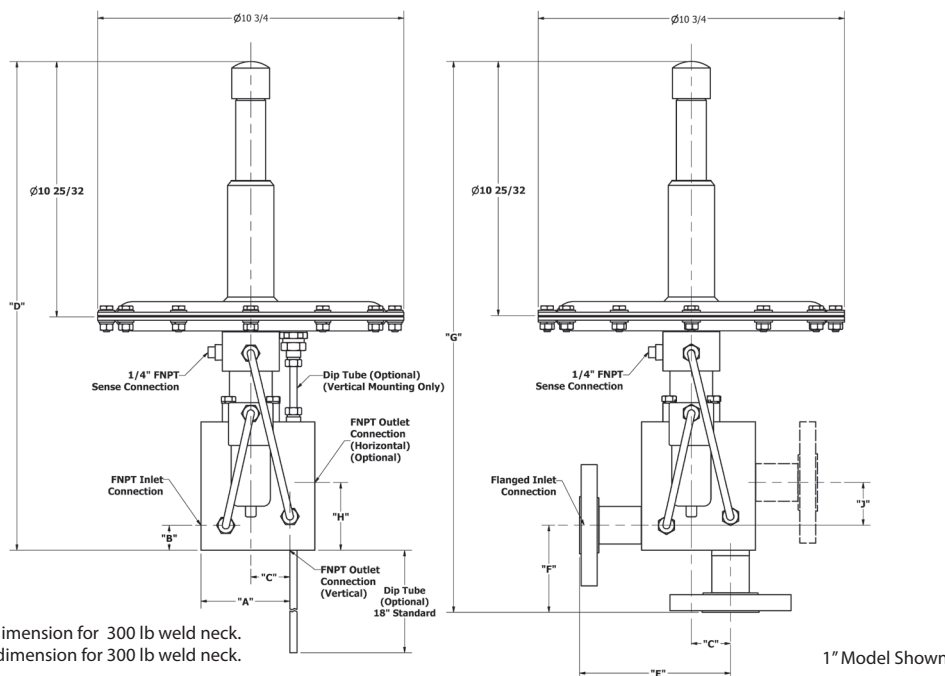

All designs subject to change. Certified dimensions and specifications available upon request.

## 94270 Ordering Guide

### Model Number Selection

The model number will consist of a base number **94270** followed by 8 digit numbers. These digits will represent 7 option tables.

**94270 - AB - CD - EF - GH**

### Ordering Information

Specify:

1. Model 94270
2. Select Size, Connection & Material
3. Select Diaphragm Type
4. Select Set Point
5. Select Flow Port
6. Select Accessories
7. Specify Inlet Pressure



### Table A - Connection

Option A	Flange Type	Thread Type
0	ANSI 150 lb RF	NPT
1	EN1092-1 DN 15 PN16 RF	----
2	EN1092-1 DN 25 PN16 RF	----
3	ANSI 150 lb RF Weld Neck*	----
4	ANSI 300 lb RF Weld Neck*	----

\* Weld neck flange only available on 1" and 2" model  
Other flange types available upon request.

### Table B - Size, Connection and Material

Size	Type of Connection	Material			
		304 SS Body/CS Diaphragm Housing Option B	316 SS Body Diaphragm Housing Option B	316 SS Body Lower Diaphragm Housing / CS Upper Option B	316 SS Body/CS Diaphragm Housing Option B
1/2"	Threaded	1	2	9	D
1/2"	Flanged	3	4	A	E
1"	Threaded	5	6	B	F
1"	Flanged	7	8	C	G
2"	Threaded	H	K	M	P
2"	Flanged	J	L	N	R

**Table C - Outlet**

Option C	Outlet
0	Vertical
1	Horizontal

**Table D - Diaphragm & Seals**

Option D	Diaphragm	Seals
1	NBR	NBR
2	FKM	FKM
3	FEP	FKM
4	FEP	EPDM
5	FEP	FFKM
7	FEP	NBR

**Table E - Accessories**

Option E	Accessories
0	*Standard
1	1/2" Zinc Inlet Filter
3	1/2" Stainless Steel Inlet Filter
4	1" & 2" Stainless Steel Pilot Filter
5	1/2" Zinc Inlet Filter with Check Valve
6	1" & 2" Aluminum/Zinc Pilot Filter with Check Valve
7	1/2" Stainless Steel Inlet Filter with Check Valve
8	1" & 2" Stainless Steel Pilot Filter with Check Valve
9	Inlet and outlet Pressure Gauges
A	1" & 2" Aluminum/Zinc Pilot Coalescing Filter

\*Standard Construction Includes the following:  
 1/2" - No Filters or Check Valves,  
 1" & 2" - Aluminum/Zinc Pilot Filter, No Check Valves

**Table F - Set Point Selection**

Range	0.5 - 2" W.C.	1.9 - 4" W.C.	3.5 - 10" W.C.	9 - 20" W.C.	18 - 29" W.C.	27 - 39" W.C.	1.3 - 1.8 PSIG	1.7 - 2.3 PSIG	2.2 - 3 PSIG	2.9 - 5 PSIG	4.9 - 10 PSIG	9.9 - 15 PSIG
Option F	1	2	3	4	5	6	7	8	9	A	B	C

**Table GH - Size, Sense, & Flow Port**

Size	Sense	Option GH						
		% of Standard Flow Port						
		200%	150%	100%	75%	50%	25%	10%
1/2"	External	06	04	01	08	20	23	N/A
	Dip Tube*	07	05	02	09	21	22	N/A
	Internal*	N/A	N/A	N/A	N/A	N/A	03	N/A
1"	External	N/A	N/A	11	12	13	14	10
1"	Dip Tube*	N/A	N/A	16	17	18	19	15
2"	External	N/A	N/A	24	25	26	27	28

\*Vertical Mount Only