

94065 FRP Manhole Cover (Pressure & Vacuum)

The Shand & Jurs 94065 FRP (Fiberglass Reinforced Plastic) Series Manhole Cover is designed to provide emergency venting and vacuum relief of low-pressure storage tanks and vessels. These covers also provide quick, easy access for tank inspection and maintenance. When the tank is exposed to abnormal internal pressure or vacuum beyond the capability of the conservation vent, the manhole protects the tank against costly rupture.

The Shand & Jurs 94065 FRP Series Manhole Cover provides an effective vapor-tight seal until pressure or vacuum relief is required to protect the tank. Under emergency conditions, the cover opens fully to allow escape of vapors and prevents damage to the tank. Under vacuum conditions, the spring-loaded vacuum vent will open to relieve excessive negative pressure.

Construction

Standard:

Flange, Seat, and Pallets of Derakane 470 Vinyl Ester Resin. 316 Stainless Steel Trim (Hastelloy optional) and Teflon® Air Cushioned Pallet Seating.

Custom:

Other resins, soft goods, trim and hardware materials are available to meet exact corrosion requirements including 411 Derakane and Furan Hastelloy.

Fast Inspection, Easy Maintenance

Unit's rugged and lightweight design provides for easy, convenient handling for installation, inspection and maintenance. The pressure cover is normally restrained to allow automatic reseating. Disconnection of the retaining cord allows the pressure vent cover to be completely removed, thereby allowing access into the tank through the full diameter seat opening. Facilitates tank inspection and repair procedures.

Maintains Accurate Pressure Setting

Factory tested prior to shipment to meet Shand & Jurs high standards. Standard pressure setting of 3/4 oz/in² on all models. Standard vacuum relief setting is 1/2 oz/in². Higher settings are also available.

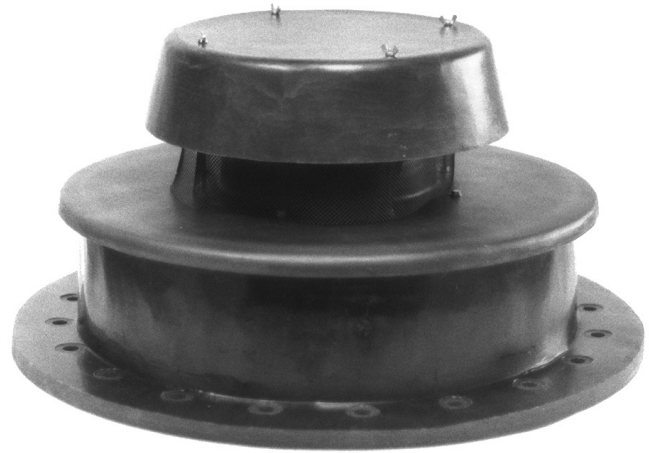

Features

- 20" & 24" sizes. Other sizes available
- Acids & caustic services
- Fiberglass construction
- API 650, ANSI 150 or EN1092-1 flange drilling
- Leakage Rate of ≤ 1 SCFH at 90% of Set Point
- 470 Derakane standard, 411 Derakane and Furan available

Dimensions:

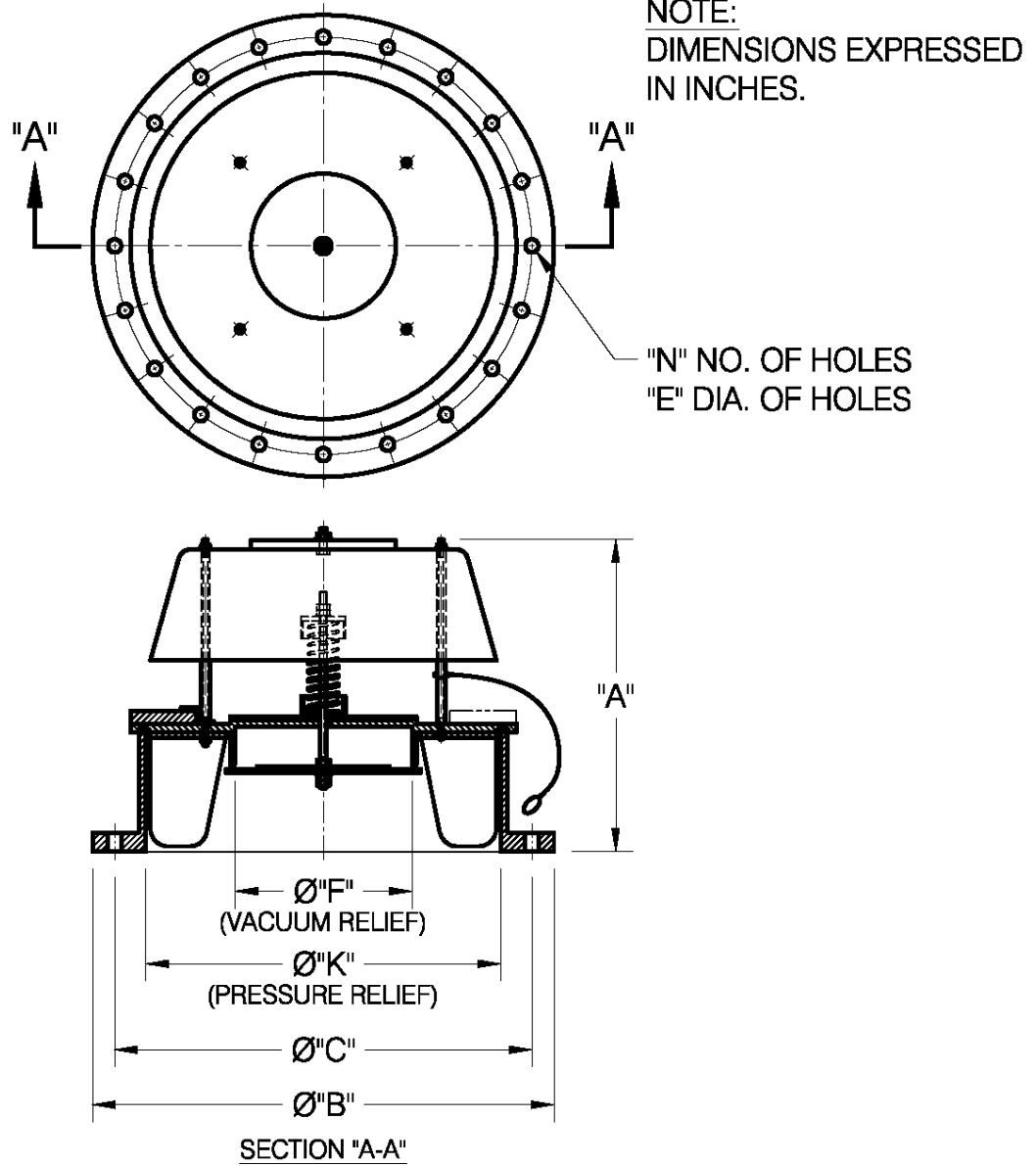

Size	"K"	"A"	"B"	"C"	"E"	"N"	"F"
20" API	20	17 ¼	26	23 ½	¾	16	9 15/16
20" ANSI	20	17 ¼	27 ½	25	1 ¼	20	9 15/16
24" API	24	17 ¼	30	27 ½	¾	20	9 15/16
24" ANSI	24	17 ¼	32	29 ½	1 ⅜	20	9 15/16

Consult Factory for other sizes.

All designs subject to change. Certified dimensions and specifications available upon request.

94065 Ordering Guide

Model Number Selection

The model number will consist of a base number **94065** followed by 6 digit numbers. These digits will represent 5 sets of option tables.

94065 - AB - CD - EF

Ordering Information

Specify:

1. Model 94065 Fiberglass Reinforced Plastic Manhole Cover
2. Type of Size
3. Type of Pressure Setting
4. Temperature Range
5. Flange Type
6. To Specify CE for Ordinary EU Locations use 94065CAB-CD-EF

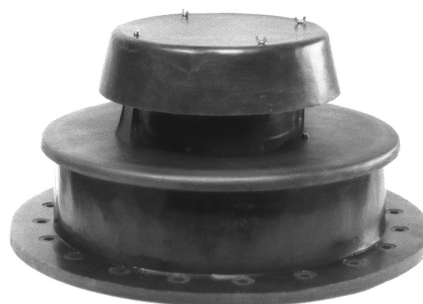

Table AB - Size

Option AB	Size (Inches)
16	16"
18	18"
20	20"
24	24"

Table C - Pressure Setting & Load Weight

Option C	Pressure Setting oz/in ²	Load Weights
3	.75 - 1.5	Encapsulated Weights
4	1.5 - 4.0	

* Maximum Pressure Setting is 4 oz/in²
(Higher Set Points Available, Consult Factory)

Table D - Material

Option D	Body Material
1	411 Derakane
2	470 Derakane
3	Furan

Table E - Flange Type

Option E	Flange Type
0	ANSI 125/150 lb. FF
1	EN1092-1 PN10 FF
2	*API 650 FF
3	UL 142 FF

* API 650 Flange Available in 20" and 24" sizes only.

Table F - Construction

Option F	Construction
0	Standard
2	Hastelloy C Stud & Nuts
3	Hastelloy C Stud & Nuts and Extra Corrosion

NOTE: Hood Wing Nuts, Hold Down Clamp and Retaining Cable is 316SS

NOTE: For HCL environment up to 36% volume specify corrosion barrier and encapsulated weights