



- Cost effective, dual purpose
- Provides pressure & vacuum relief
- Serves as a barrier between external flame and internal vapors
- Provides protection against flame propagation
- Optional steam jacketing
- Open or closed vent configurations
- Sizes 2" thru 12" ANSI and DIN

The Shand and Jurs Model 97570 Combination Conservation Vent & Flame Arrester

The Shand and Jurs Model 97570 Combination Conservation Vent and Flame Arrester is a single, easy to configure package providing for pressure and vacuum relief, as well as positive flame stop on low pressure tanks containing flammable liquids or solvents having a low flash point.

The conservation vent features cushion seated diaphragms constructed of FEP Teflon for reliability,

and extended service life. For high reliability, the pressure and vacuum pallets are both peripherally and center stem guided.

The unitized tube bank provides maximum flow while minimizing pressure drop. Both body and tube banks are available in numerous materials to meet the requirements of your site.

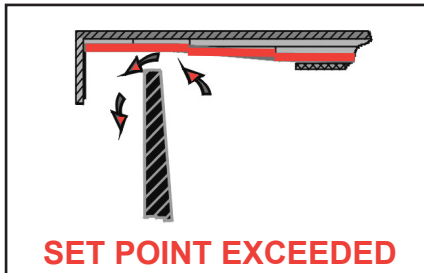
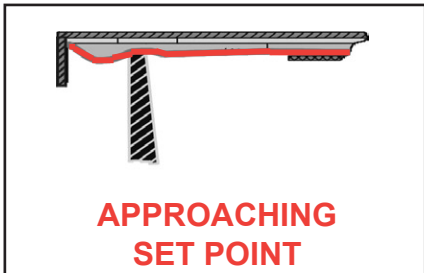

Shand & Jurs "Expanda-Seal" option is available on all pressure pallet assemblies. This feature, shown in red, significantly reduces leakage. The ballooning effect of the teflon diaphragm effectively seals the valve. The "Expanda-Seal" feature ensures less than .5 SCFH of leakage at 95% of the set point.

OUTLINE DIMENSIONS

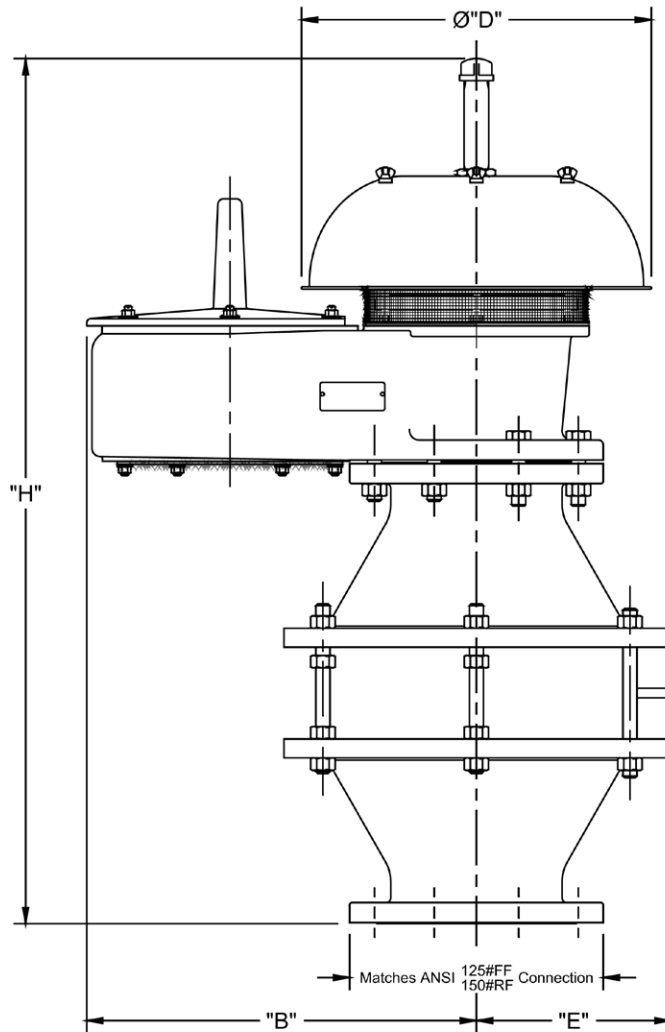

Vent Size	"B"	Diameter "D"	"E"	"H"
2"	8 13/16	12 7/8	7 5/8	26 9/16
3"	11 3/16	13 9/16	8 5/16	29 7/16
4"	13 9/16	15 15/16	6 13/16	33 11/16
6"	16 11/16	18 5/8	8 1/4	38 11/16
8"	20 1/2	18 5/8	10 1/4	45 13/16
10"	24 11/16	25 9/16	12 1/4	57 1/16
12"	29 1/16	29 7/8	14 3/8	65 3/16

All designs subject to change. Certified dimensions and specifications available upon request

MODEL NUMBER SELECTION:

The model number will consist of a base number 97570 followed by 9 digits which represent the options listed in the following tables.

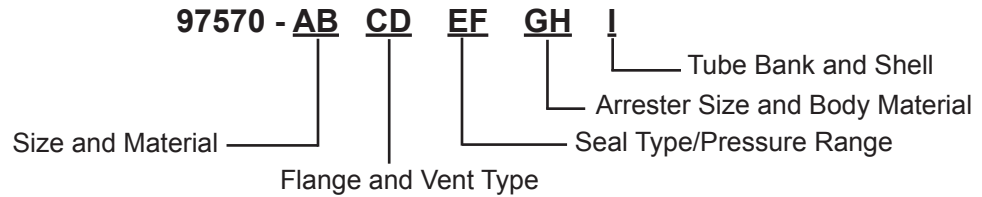

ORDERING INFORMATION

Specify:

1. Size and body material
2. Type of flange
3. Tube bank and shell material
4. Closed or open vent
5. Pressure and vacuum settings if not standard
6. Optional materials of construction or coatings, if required



TABLE I - SIZE AND BODY MATERIAL

OPT (AB)	SIZE	TYPE OF CONNECTION	BODY MATERIAL
11	2"	NPT	ALUM
12	2"	Flanged	ALUM
21	2"	NPT	ALUM CRYO HOOD
22	2"	Flanged	ALUM CRYO HOOD
*31/41	2"	NPT	CI/DI
*32/42	2"	Flanged	CI/DI
51	2"	NPT	CS
52	2"	Flanged	CS
71	2"	NPT	316 SS
72	2"	Flanged	316 SS
13	3"	NPT	ALUM
14	3"	Flanged	ALUM
23	3"	NPT	ALUM CRYO HOOD
24	3"	Flanged	ALUM CRYO HOOD
*33/43	3"	NPT	CI/DI
*34/44	3"	Flanged	CI/DI
53	3"	NPT	CS
54	3"	Flanged	CS
73	3"	NPT	316 SS
74	3"	Flanged	316 SS
15	4"	Flanged	ALUM
25	4"	Flanged	ALUM CRYO HOOD
*35/45	4"	Flanged	CI/DI

OPT (AB)	SIZE	TYPE OF CONNECTION	BODY MATERIAL
55	4"	Flanged	CS
75	4"	Flanged	316 SS
16	6"	Flanged	ALUM
26	6"	Flanged	ALUM CRYO HOOD
*36/46	6"	Flanged	CI/DI
56	6"	Flanged	CS
76	6"	Flanged	316 SS
17	8"	Flanged	ALUM
27	8"	Flanged	ALUM CRYO HOOD
*37/47	8"	Flanged	CI/DI
57	8"	Flanged	CS
77	8"	Flanged	316 SS
18	10"	Flanged	ALUM
28	10"	Flanged	ALUM CRYO HOOD
*38/48	10"	Flanged	CI/DI
58	10"	Flanged	CS
78	10"	Flanged	316 SS
19	12"	Flanged	ALUM
29	12"	Flanged	ALUM CRYO HOOD
*39/49	12"	Flanged	CI/DI
59	12"	Flanged	CS
79	12"	Flanged	316 SS

* 3X = Cast Iron, 4X = Ductile Iron

TABLE II - FLANGE TYPE

OPT (C)	DESCRIPTION
0	FF
1	RF*
2	DIN 2633 PN 16 FF
3	DIN 2633 PN 16 RF*
4	JIS 10K FF
5	JIS 10K RF*

* Raised face flanges not available with aluminum bodies.

TABLE III - VENT TYPE

OPT (D)	DESCRIPTION
1	Open Vent
2	Open Vent w/ Flame Snuffer
3	Closed, Standard Outlet > Inlet
4	Pipe Away, P&V
6	Pipe Away, Same Size in, out, Seat*

* Replaced Option 5
Dimensions are not identical

TABLE IV - SEAL TYPE

OPT (E)	SEAL TYPE & SOFT GOODS
0	Normal FEP Teflon/N8090
1	Expanda Seal FEP Teflon/N8090
2	Normal FEP Teflon (all)
3	Expanda FEP Teflon (all)
4	Normal Viton (all)
5	Expanda Viton (all)
6	Normal PTFE
8	Normal Buna Diaphragm
9	Expanda Buna Diaphragm

TABLE V - PRESSURE RANGE

OPT (F)	Description	Weight Material
1	Std Pres and Vac Set = .5oz./sq.in.	Lead
2	Over 2.9 oz/sq. in.	Lead
3	Standard to 2.9 oz/sq.in.	Lead
4	Standard Setting	316 SS
5	Over 2.9 oz/sq. in.	316 SS
6	Standard to 2.9 oz/sq.in.	316 SS

Expanda-Seal Pressure Setting:
1.5 oz./sq. in. Minimum
(Consult Factory for lower settings)

TABLES IV & V

TABLE IV - (GH) SIZE AND BODY TABLE V - (I) TUBE BANK AND SHELL

OPTION # (GH)	SIZE (INCHES)	BODY MATERIAL	OPTION # (I)	TUBE BANK MATERIAL	SHELL MATERIAL
12	2	ALUMINUM	1	ALUMINUM	ALUMINUM
12	2	ALUMINUM	6	304 SS	CS
12	2	ALUMINUM	2	316 SS	316 SS
14	3	ALUMINUM	1	ALUMINUM	ALUMINUM
14	3	ALUMINUM	6	304 SS	CS
14	3	ALUMINUM	2	316 SS	316 SS
15	4	ALUMINUM	1	ALUMINUM	ALUMINUM
15	4	ALUMINUM	6	304 SS	CS
15	4	ALUMINUM	2	316 SS	316 SS
16	6	ALUMINUM	1	ALUMINUM	ALUMINUM
16	6	ALUMINUM	6	304 SS	CS
16	6	ALUMINUM	2	316 SS	316 SS
17	8	ALUMINUM	1	ALUMINUM	ALUMINUM
17	8	ALUMINUM	6	304 SS	CS
17	8	ALUMINUM	2	316 SS	316 SS
18	10	ALUMINUM	1	ALUMINUM	ALUMINUM
18	10	ALUMINUM	6	304 SS	CS
18	10	ALUMINUM	2	316 SS	316 SS
19	12	ALUMINUM	1	ALUMINUM	ALUMINUM
19	12	ALUMINUM	6	304 SS	CS
19	12	ALUMINUM	2	316 SS	316 SS
32,62	2	CI,DI	6	304 SS	CS
32,62	2	CI,DI	2	316 SS	316 SS
52	2	CS	6	304 SS	CS
52	2	CS	2	316 SS	316 SS
42	2	SS 316	2	316 SS	316 SS
34,64	3	CI,DI	6	304 SS	CS
34,64	3	CI,DI	2	316 SS	316 SS
54	3	CS	6	304 SS	CS
54	3	CS	2	316 SS	316 SS
44	3	SS 316	2	316 SS	316 SS
35,65	4	CI,DI	6	304 SS	CS
35,65	4	CI,DI	2	316 SS	316 SS
55	4	CS	6	304 SS	CS
55	4	CS	2	316 SS	316 SS
45	4	SS 316	2	316 SS	316 SS
36,66	6	CI,DI	6	304 SS	CS
36,66	6	CI,DI	2	316 SS	316 SS
56	6	CS	6	304 SS	CS
56	6	CS	2	316 SS	316 SS
46	6	SS 316	2	316 SS	316 SS
37,67	8	CI,DI	6	304 SS	CS
37,67	8	CI,DI	2	316 SS	316 SS
57	8	CS	6	304 SS	CS
57	8	CS	2	316 SS	316 SS
47	8	SS 316	2	316 SS	316 SS
38,68	10	CI,DI	6	304 SS	CS
38,68	10	CI,DI	2	316 SS	316 SS
58	10	CS	6	304 SS	CS
58	10	CS	2	316 SS	316 SS
48	10	SS 316	2	316 SS	316 SS
39,69	12	CI,DI	6	304 SS	CS
39,69	12	CI,DI	2	316 SS	316 SS
59	12	CS	6	304 SS	CS
59	12	CS	2	316 SS	316 SS
49	12	SS 316	2	316 SS	316 SS

RAISED FACE FLANGES NOT AVAILABLE WITH ALUMINUM BODIES

CI = Cast Iron
DI = Ductile Iron
CS = Cast Steel
304 SS = Cast 304 Stainless Steel
316 SS = Cast 316 Stainless Steel