

- Upstream or Downstream Control
- Balanced Double Port/Plug Design
- Large Diaphragm for Increased Sensitivity
- Externally Adjustable Set Point with Visual Indicator
- Fewer Moving Parts for Longer Service Life
- No External Power Source Required

## The Shand & Jurs Model 97177 Double Port Regulator

The S&J 97177 Double Port Regulator provides sensitive control at a preset upstream or downstream pressure (up to 20" w. c.) in biogas lines such as those in low pressure digesters, landfills, lagoons and other fermentation processes. The regulator is a balanced, double ported valve that is actuated through a mechanical offset by a large spring-loaded diaphragm. The valve can be configured as a backpressure (upstream) regulator to provide reliable control of gas flow or as a pressure-reducing (downstream) regulator, which will maintain a constant downstream pressure.

**Backpressure Regulator:** Valve opens when upstream pressure exceeds set point.

**Pressure Reducing Regulator:** Valve opens when downstream pressure drops below set point.

Field adjustment of the set point is easily done by adjustment of the diaphragm spring, which is provided with a visual indicator.

The valve is available in two standard pressure ranges, from 1" to 10" w. c. and 10" to 20" w. c. Standard sizes are 2" through 8" flanged connections with an optional 1" NPT connection available (consult factory). A 1" NPT external sense connection is provided. Connection should be made a minimum of 10 feet from the regulator.

The S&J 97177 is especially designed for hydrogen sulfide and hot, wet methane, which are the main components of digester gas streams in municipal wastewater treatment facilities. Standard materials of construction include aluminum, carbon steel or cast iron body with aluminum diaphragm housing (consult factory for other materials). All internal trim material is constructed from 304 stainless steel. The standard diaphragm material is Nylon reinforced Buna N with optional Viton and Teflon materials available (consult factory). The combination of these components will withstand the severest of process environments. The 97177 is 100% U.S. made.

## Applications

- Anaerobic digester gas train**
- Fermentation off gas piping systems**
- Low pressure vent lines**

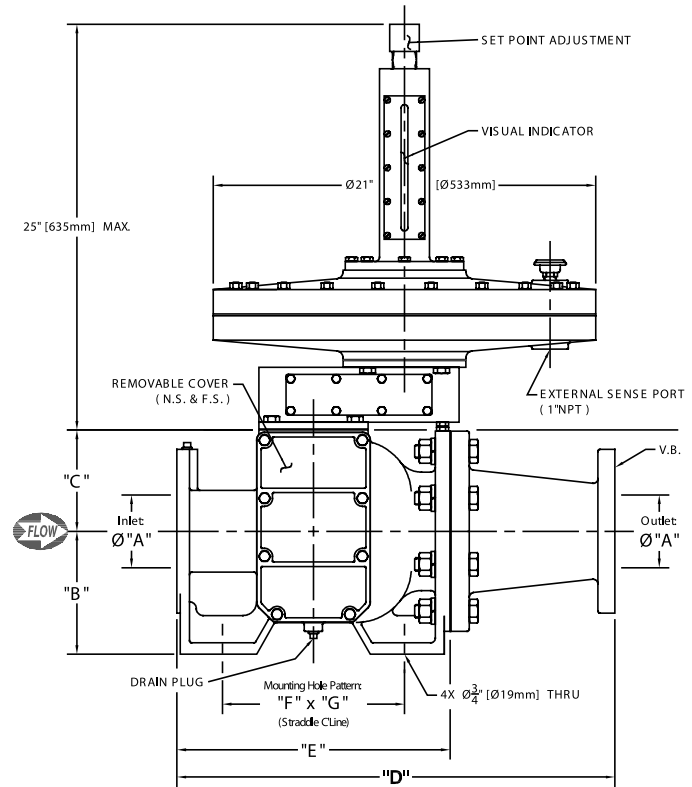
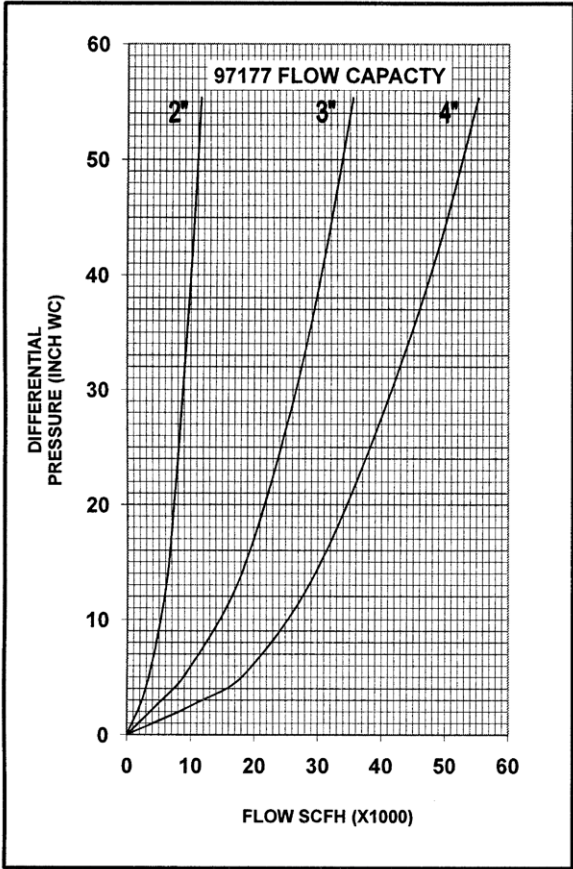

VALVE SIZE	TABLE OF DIMENSIONS						
	"A"	"B"	"C"	"D"	"E"	"F"	"G"
2"	2"	6-3/4"	4"	17-1/8"	11"	8"	2-1/4"
3"	3"	6-3/4"	4-3/4"	19-1/8"	12"	8-1/2"	3"
4"	4"	6-3/4"	5-5/8"	24-1/16"	15"	10"	4"
6"	6"	10-1/4"	7-1/2"	29-3/16"	18"	13-1/2"	4-1/2"
8"	8"	12-1/2"	9-1/2"	35-15/16"	23-7/8"	16-7/8"	6"

### HOW TO ORDER

97177 - **A** **B** **C** **D**

VALVE BODY (V.B.) MATERIAL \_\_\_\_\_ VALVE CONFIGURATION \_\_\_\_\_  
 LINE SIZE \_\_\_\_\_ SETTING RANGE \_\_\_\_\_

<u>Valve Body (V.B.)</u>	<u>Size</u>	<u>Setting Range</u>	<u>Valve Configuration</u>
<u>Material</u>	1 = 1"	1 = Standard Pressure Range (1" to 10")	1 = Back Pressure Configuration
1 = AL	2 = 2"	2 = High Pressure Range (10" to 20")	2 = Pressure Reducing Configuration
2 = CS*	3 = 3"	See 97170 for lower pressure ranges.	
3 = CI*	4 = 4"		
	6 = 6"		
	8 = 8"		

\*Upper Diaphragm Housing is AL (STD)

All designs subject to change. Certified dimensions and specifications available upon request.