



- Positive Gas Shut-off While Draining
- 100 PSI Standard
- 4 Quart Capacity
- Locking Lever

The Shand & Jurs 97101 High Pressure Manual Drip Trap

The S&J 97101 High Pressure Manual Drip Trap provides for the continuous, safe removal of condensate from low points in pressure gas piping systems. Removing condensed liquid protects the piping and equipment from corrosion and “water hammer” damage.

The unit collects liquid until the drain valve is manually opened. The inlet valve is closed prior to opening the drain port allowing for removal of condensate without gas escaping.

High and low pressure rated units allow for use in any low area of the digester gas system. For lower operating pressures, the model 97100 and 97110 drip traps are recommended.

Available in 4 quart size and with 1” NPT inlets and outlets, the S&J 97101 adapts to any condensation or drainage collection requirement. Its carbon steel and stainless steel components withstand the severest of process environments. The S&J 97101 is especially designed for hydrogen sulfide and hot, wet methane which are the main components of digester gas streams in municipal waste water treatment facilities.

The 97101 is 100% U.S. made.

Applications

Anaerobic digester gas train
Fermentation off gas piping systems
Compressor discharge piping

SPECIFICATIONS

Available Sizes/Capacity: 4 Quart

Inlet/Outlet Connections: 1" NPT

Materials of Construction:

Standard: Carbon Steel Body, Brass Ball Valve, Teflon Seat

Optional: Stainless Steel Body and Ball Valve, Teflon Seat

Maximum Working Pressure: 100 PSIG

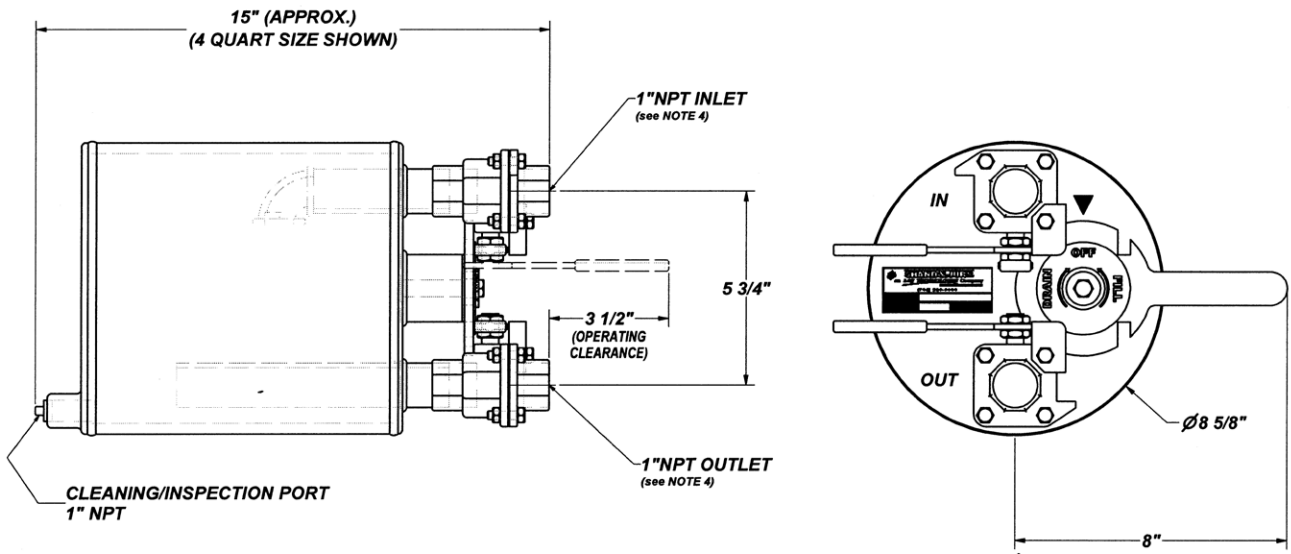

HOW TO ORDER

97101 - A B

Capacity _____ Material

(A) Capacity	(B) Material
4 = 4 Quart	0 = Steel Body, Brass Ball Valve, Teflon Seat
	1 = Stainless Steel Body and Ball Valve, Teflon Seat

Design subject to change without notice