



- Operates to 1000 PSIG
- Model 96900-01 - Standard Pressure Control
- Model 96900-02 - Includes outside pressure release
- Model 96900-03 - Pneumatically operated pressure release
- Model 96900-05 - Includes deadman pressure release

The Shand & Jurs Model 96900 Hydraulic Pump Unit

The Shand & Jurs Series 96900 Hydraulic Operators are used specifically to operate Shand & Jurs Internal Safety and Shutoff Valves. These operators are available in different models and supply the hydraulic operating pressure required for valve actuation.

The Shand & Jurs Model 96900-01 Hydraulic Operator has a hydraulic hand pump with a series of check valves which maintain pressure in the system and permit multiple short strokes of the handle to build up the desired pressure. This operator produces approximately 1000 psi of pressure. The standard operator includes such items as pressure gauge, oil strainer and internal sediment basin.

The Shand & Jurs Model 96900-02 Hydraulic Operator is identical to Model 96900-01, except that it includes an outside trip which manually releases pressure.

The Shand & Jurs Model 96900-3 Hydraulic Operator with Grad-U-Motor is operated by applying air pressure (15 psig) into the chamber above the operator. As a result the stem and the piston moves downward and depresses the check valve. Now, the pump handle can be operated and the valves opened. Hydraulic pressure is maintained on the valves holding them in the open position. Release of air pressure automatically allows the check valve to open, thus reducing hydraulic pressure and closing the valves.

The Shand & Jurs Model 96900-05 Hydraulic Operator with Deadman Control functions the same as the standard operator, except the relief lever must be depressed for operation. Releasing the lever, automatically releases the pressure that results in valve closure.

Optional 1500 psi pressure operator available, consult factory.

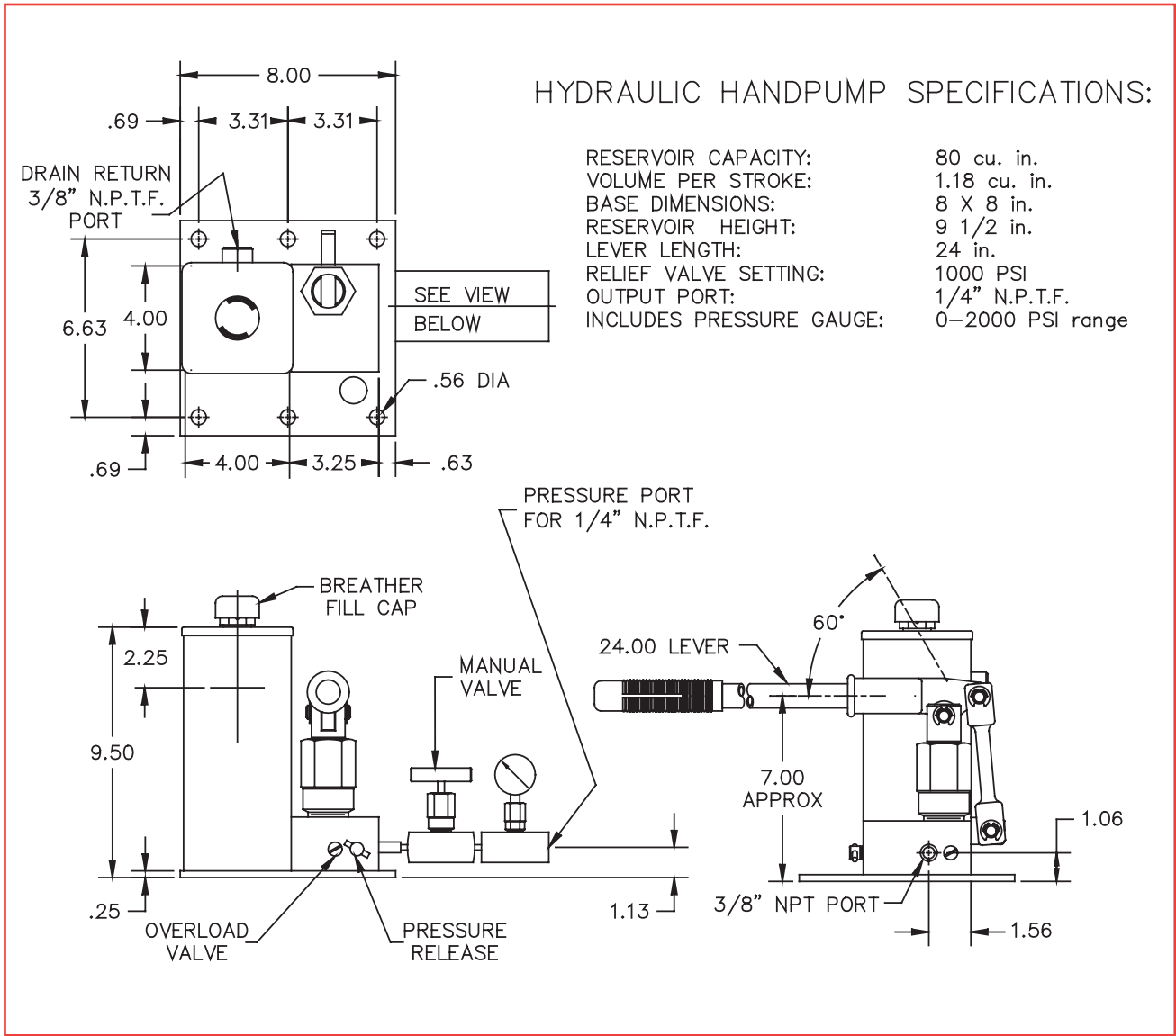

All designs subject to change. Certified dimensions and specifications available upon request

MODEL NUMBER SELECTION:

The model number will consist of a base number 96900 followed by 2 digits which represent the options listed in the following tables.

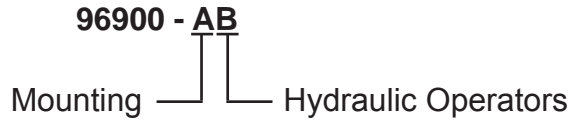

TABLE I - (A) MOUNTING

MODEL #	DESCRIPTION
0	Bottom Mount (Standard)
1	Side Mount

TABLE II - (B) HYDRAULIC OPERATORS

MODEL #	DESCRIPTION	WEIGHT (lbs.) Approximate
1	Standard	20
2	w/outside trip	21
3	w/grad-u-motor	25
5	w/deadman control	C.F.

PROTECTIVE DEVICES

MODEL #	DESCRIPTION	SPECIFY
97086-01	1/8" NPT Fusible Plug (212° F)	JA7086-1
97086-02	1/2" NPT Fusible Plug (200° F)	(consult factory)
97087-01	Fusible Link	216-2
97088-01	Frangible Element	JA7088-1