



- Low copper aluminum alloy construction
- Reduced need for special materials in corrosive and extreme temperature
- Peripheral and stem guided pressure pallet assures smooth lift and closure
- Positive seal and minimal blow down
- Capacity certified to API standards
- Reduced maintenance and installation costs

The Shand & Jurs Model 94130 Pressure Relief Vent (Open or Closed Vent Option)

The Shand & Jurs Model 94130 Pressure Relief Vent is designed to provide pressure relief with high efficiency, maximum flow capacity and minimum leakage. The easily serviceable configuration and light weight construction reduces maintenance and installation costs. A variety of construction materials are available as part of the standard design which are ideally suited for highly corrosive and toxic product applications.

For dependable performance, Shand & Jurs Pressure Relief Vents utilize pressure pallets that are both peripherally and center stem guided. The standard diaphragm is "Air Cushion Seated" and constructed of teflon for high resistance to adhesion of ice and gum formation. A range of sizes and configurations, such as closed vent hood and flame snuffers are available. Standard pressure setting is 0.5 oz. per square inch.

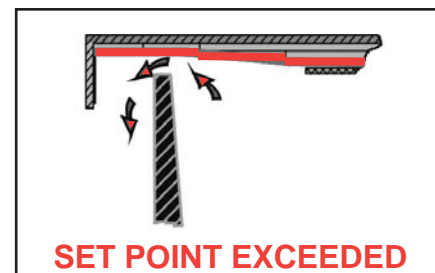
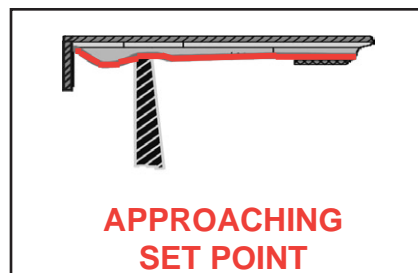
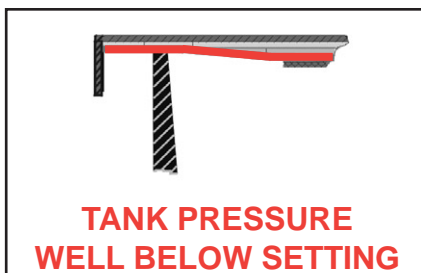

The Shand & Jurs "Expand-Seal" option is available on all pressure pallet assemblies. This feature, shown in red, significantly reduces leakage. The ballooning effect of the teflon diaphragm effectively seals the valve. The "Expand-Seal" feature ensures less than .5 SCFH of leakage at 95% of the set point.

SPECIFICATIONS:

Sizes:2", 3", 4", 6", 8", 10" & 12"
 *Maximum
 Setting:24 oz./sq. in.
 Standard
 Setting:0.5 oz./sq. in. (.86 in. W.C.)

Expanda-Seal Pressure Setting:
 1.5 oz./sq. in. Minimum
 (Consult Factory for lower settings)

Temperature Range: Body and Seal
 Options for Process Temperature Ranges of
 -300°F to 500°F

Raised face (except alum.) or flat face flange
 available; compatible with ANSI 150 lb.
 DIN and JIS 10K flanges available.

* Varied by valve size and weight material.
 Please consult factory for particular valve
 size and weight material.

MATERIALS OF CONSTRUCTION:

Body:..... Cast Aluminum, Cast Steel, Cast Iron,
 Ductile Iron or 316 Stainless Steel

Closed Vent Cover:..... Cast Aluminum, Steel or
 Stainless Steel

Pallet:..... Aluminum or Stainless Steel

Seat: Aluminum or Stainless Steel
 (Field Replaceable)

Stem & Guide Posts: Aluminum, Galvanized Steel,
 Galvanized Iron or Stainless Steel

Screen: Galvanized Steel or Stainless Steel

Diaphragm: FEP Teflon

Back-up Disc: N-8090

Closed Vent Cover Gasket: . N-8090

* Table D Option 5 for same size inlet and outlet connections has
 been Obsolete and Replaced by Table D Option 6. Option 5 and
 6 dimensions do not match. Consult factory if replacement valve is
 required.

94130 Closed Vent

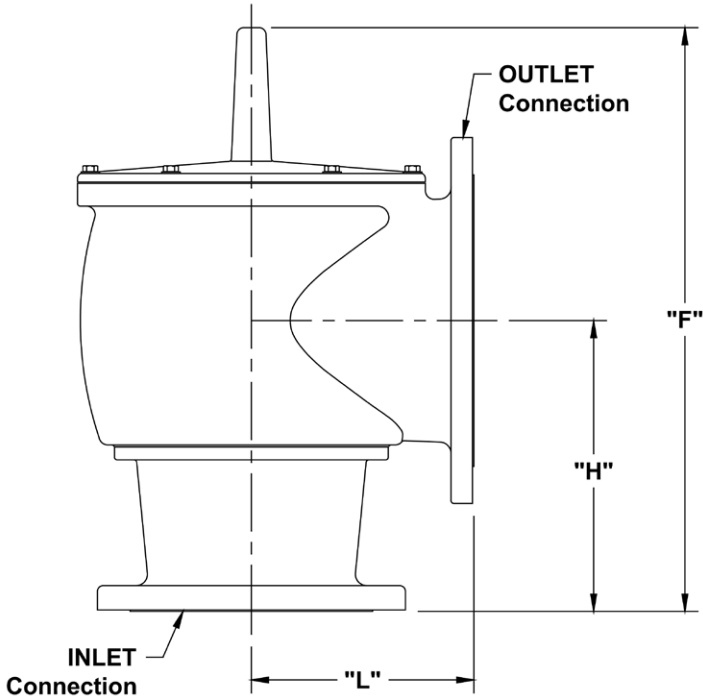

Valve Size	"F"	"H"	"L"
2" X 2"	11 1/8	5 1/32	4 1/4
2" X 3"	11 1/8	5 1/32	4 1/4
3" X 3"	13 1/4	5 9/16	5 1/4
3" X 4"	13 3/4	5 31/32	5 1/4
4" X 4"	20 3/8	7	6 1/2
4" X 6"	15 3/4	7 1/32	5 15/16
6" X 6"	21 1/4	9 3/8	8 3/8
6" X 8"	21 1/4	10 11/32	8 1/4
8" X 8"	25 1/2	11 11/16	9 3/4
8" X 10"	26 3/16	12 23/32	9 3/4
10" X 10"	30	13 7/8	11 19/32
10" X 12"	30 1/4	14 29/32	11 19/32
12" X 12"	33 7/8	16 1/4	12 13/16
12" X 14"	33 7/8	16 7/8	12 13/16

All designs subject to change. Certified dimensions and specifications available upon request

94130 Open Vent

Valve Size	"D"	Diameter "E"
2"	11 1/8	12 7/8
3"	13 3/4	13 9/16
4"	15 3/4	15 15/16
6"	18 3/4	18 5/8
8"	21 1/4	18 5/8
10"	28 1/8	25 9/16
12"	32 1/4	29 7/8

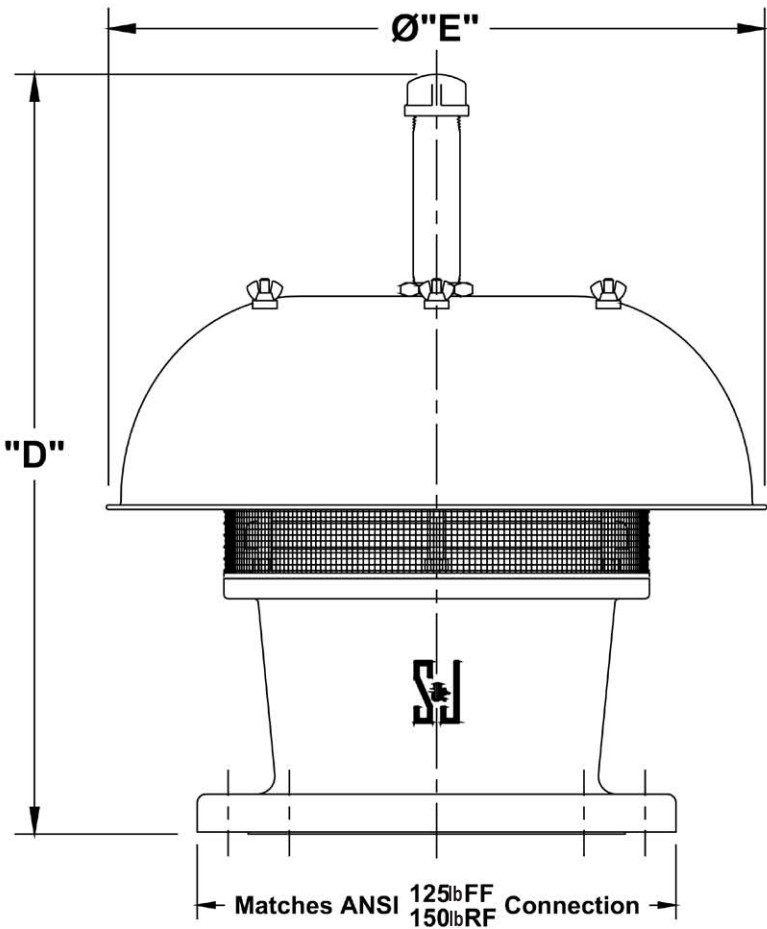

All designs subject to change. Certified dimensions and specifications available upon request

MODEL NUMBER SELECTION:

The model number will consist of a base number 94130 followed by eight values which represent the options listed in the following tables.

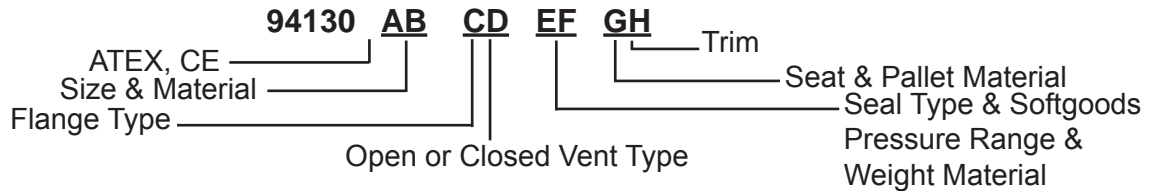

ORDERING INFORMATION

Specify:

1. Model 94130 Pressure Relief Vent
2. Size and Body Material
3. Type of Venting
 - A) Open Vent
 - B) Closed Vent
4. Pressure Setting Required
5. Cleaning for Oxygen Service or Other Special Cleaning
6. Optional Materials of Construction, If Required
7. To Specify CE for Ordinary EU Locations use 94130C AB CD EF GH
8. To Specify ATEX Certification for Group IIB, IIA EU Locations use 94130A AB CD EF GH. ATEX Certification Includes CE Mark.



STANDARD MATERIALS OF CONSTRUCTION

Service	Body	Open Vent Hood		Seat		Pallets	Stem Guide Tube	Screen	Side Guides
		2,3,4, 6&8	10 & 12	2,3,4	6,8 10 & 12				
Norm. Alum.	Cast Alum.	18-8	Alum.	Alum.	Alum.	Alum.	Galv. Iron	Galv. Steel	316ss
Cyro Low. Temp.	Cast Alum.	Alum	Alum.	Alum.	Alum.	Alum.	316ss	304ss	316ss
Severe Iron	CI/DI	18-8	Alum.	316ss	316ss	316ss	Galv. Iron	304ss	316ss
Severe Steel	Cast Steel	18-8	Alum.	316ss	316ss	316ss	Galv. Iron	304ss	316ss
Severe 316ss	Cast 316ss	316ss	316ss	316ss	316ss	316ss	316ss	316ss	316ss

Service	Pallet Stem Pressure	Diaph.	Closed Vent Cover		Cover Gaskets	Hardware
			2,3,4	6,8,10,12		
Norm. Alum.	316ss	FEP	Alum.	Alum.	N-8090	St. Zinc Plated
Cyro Low. Temp.	316ss	FEP	Alum.	Alum.	N-8090	316ss
Severe Iron	316ss	FEP	Steel	Steel	N-8090	316ss
Severe Steel	316ss	FEP	Steel	Steel	N-8090	St. Zinc Plated
Severe 316ss	316ss	FEP	316ss	316ss	N-8090	316ss

N-8090 = Nitrile Fiber Composition

FEP = Teflon

CI = Cast Iron DI = Ductile Iron

TABLE (AB) - SIZE/MATERIAL

TABLE 1 OPT. #	SIZE	BODY MATERIAL
12	2"	ALUM.
22	2"	AL. W/ CRYO. HOOD
32,72	2"	CAST IRON, DI
62	2"	SS 316
52	2"	STEEL
14	3"	ALUM.
24	3"	AL. W/ CRYO. HOOD
34,74	3"	CAST IRON, DI
64	3"	SS 316
54	3"	STEEL
15	4"	LOW COPPER CAST ALUM.
25	4"	AL. W/ CRYO. HOOD
35,75	4"	CAST IRON, DI
65	4"	SS 316
55	4"	STEEL
16	6"	ALUM.
26	6"	AL. W/ CRYO. HOOD
36,76	6"	CAST IRON, DI
66	6"	SS 316
56	6"	STEEL
17	8"	ALUM.
27	8"	AL. W/ CRYO. HOOD
37,77	8"	CAST IRON, DI
67	8"	SS 316
57	8"	STEEL
18	10"	ALUM.
28	10"	AL. W/ CRYO. HOOD
38,78	10"	CAST IRON, DI
68	10"	SS 316
58	10"	STEEL
19	12"	ALUM.
29	12"	AL. W/ CRYO. HOOD
39,79	12"	CAST IRON, DI
69	12"	SS 316
59	12"	STEEL

DI = Ductile Iron

TABLE (C) - FLANGE TYPE

OPTION	FLANGE TYPE
0	FF ANSI 150 lb
1	RF ANSI 150 lb*
2	DIN 2633 FF
3	DIN 2633 RF*
4	JIS 10K FF
5	JIS 10K RF*

* RF not available in Aluminum

TABLE (D) - VENT TYPE

OPEN VENT OPTION	CLOSED VENT OPTION
1	3,6

3 = Standard; Outlet>Inlet (Outlet is one size larger than inlet, ex. 2" X 3")

6 = Same Size Inlet, Outlet & Seat

NOTE: Option 5 replaced by Option 6. Dimensions are not identical.

TABLE (E) - SEAL TYPE & SOFTGOODS

OPTION #	SEAL TYPE
0	Normal FEP / N8090
1	Expanda Seal FEP / N8090
2	Normal FEP (all)
3	Expanda FEP (all)
4	Normal Viton
5	Expanda Viton
6	Normal PTFE
8	Normal Buna-N
9	Expanda Buna-N

TABLE (F) - PRESSURE RANGE & LOAD WEIGHT MATERIAL

OPTION #	DESCRIPTION	MATERIAL
0	Standard Setting Pressure Setting = .5 oz./sq. in.**	Lead
1	>Standard to 2.9 oz/sq. in.	Lead
2	Over 2.9 oz/sq. in.	Lead
4	Standard Setting**	316 SS
5	Over 2.9 oz/sq. in.	316 SS
6	>Standard to 2.9 oz/sq. in.	316 SS

** Expanda-Seal Pressure Setting:
1.5 oz./sq. in. Minimum

TABLE (G) - SEAT & PALLET MATERIAL

OPTION #	SEAT	PALLET
0	STD*	STD*
+ 1	Teflon	
2	AL	
+ 3	Phenolic	
4	SS	
5	Teflon Coated SS	
A	STD*	316SS
+ B	Teflon	
C	AL	
+ D	Phenolic	
E	SS	
F	Teflon Coated SS	

+ These Options Not Available with ATEX Model

TABLE (H) - TRIM

OPTION #	DESCRIPTION
0	NORMAL
1	SS TRIM

Trim Includes: Stem, Stem Guide, Side Guides, Nuts, Bolts and Screen

For ATEX Certification Valves choose Option H1.