



- Less need for special materials in corrosive and extreme temperature
- Unique floating diaphragm construction assures tight seal
- Peripheral and stem guided vacuum pallet assures reliable operation
- Pallet contributes to high flow
- Heavy duty construction, yet compact enough for easy handling

## The Shand & Jurs Model 94110 Vacuum Vent

The Shand & Jurs Model 94110 Vacuum Vent has been designed utilizing over 75 years experience in the development of quality safety and conservation fittings. The function of this vent is to relieve vacuum conditions in liquid product storage tanks, and also withstand the pressure of the stored product when not operating under a vacuum.

Vacuum breathing requirements of some petroleum products may vary so much from pressure breathing, that it is sometimes desirable and more economical to have separate vents to perform these respective functions.

A minimum number of model options are required to cover the wide variety of fluids and

temperatures encountered in the petroleum, chemical and general process industries. Many trims, body materials and settings are standard options for those few conditions where standard construction is unsuited.

Standard materials of construction include low copper aluminum, steel, stainless steel or cast iron body. Metal seats are provided to withstand high pressures to which the vent may be subjected.

The body is self-draining and drip rings keep condensates from the seating surfaces. The Teflon diaphragm of the pallet has high resistance to adhesion by ice and gum formation, thus preventing sticking to the seat ring.

### STANDARD MATERIALS OF CONSTRUCTION

Service	Body	Vacuum Cover	Seat		Pallets	Stem Guides	Screen
			2,3,4	6,8 10 & 12			
Norm. Alum.	Cast Alum.	Cast Alum.	Alum.	Alum.	Alum.	Galv. Iron	Galv. Steel
Severe Iron	Cast Iron*	Cast Iron	316ss	316ss	316ss	Galv. Iron	304ss
Severe Steel	Cast Steel	Cast Steel	**316ss	**316ss	316ss	Galv. Iron	304ss
Severe 316ss	Cast 316ss	Cast 316ss	316ss	316ss	316ss	316 SS	316ss

\*(2,3,4 CI); (6,8,10,12 Steel)

\*\* SS overlay on integral seat

### STD MAX PRESSURE (PSIG)

SIZE	ALUM. PALLET	S.S. PALLET
2"	15	17.5
3"	15	8
4"	8.5	4
6"	4.0	2.25
8"	2.3	1.25
10"	1.4	1.2
12"	1.2	1.2

Service	Pallet Stem	Diaph.	Spacer	Cover Gaskets	Side Guides	Hardware
Norm. Alum.	***Al	FEP	N-8090	Buna "N" O-ring	316ss	St. Zinc Plated
Severe Iron	316 ss	FEP	N-8090	Buna "N" O-ring	316ss	316ss
Severe Steel	316 ss	FEP	N-8090	Buna "N" O-ring	316ss	St. Zinc Plated
Severe 316ss	316 ss	FEP	N-8090	Buna "N" O-ring	316ss	316ss

\*\*\* 316 ss for elevated settings

N-8090 = Nitrile Fiber Composition Non-asbestos

FEP = Teflon

### \*MAX STD VACUUM SETTING (oz / sq. in.)

SIZE	LEAD WEIGHTS	S.S. WEIGHTS
2"	7.5oz	6.0oz
3"	9oz	7.5oz
4"	10.5oz	7.5oz
6"	12oz	7.5oz
8"	13.5oz	9oz
10"	16.5oz	12oz
12"	21oz	15oz

\*Higher settings maybe available. Consult Factory

STD Vacuum Setting..... .5 oz/sq. in.  
(2" Stainless Steel Pallets .608oz./sq.in.)

Materials of construction in this equipment have been selected as representing the most suitable commercially available material for use in the service intended. However, they do not constitute a guarantee against corrosion since processes vary from plant to

plant and concentration of harmful fluids, gasses or solids vary from time to time in a given process. Empirical experience by users should be the final guide and alternate materials based on this are generally available.

## Principle of Operation

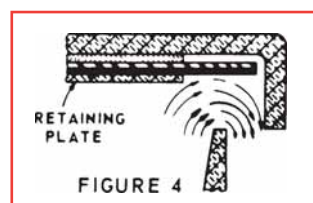
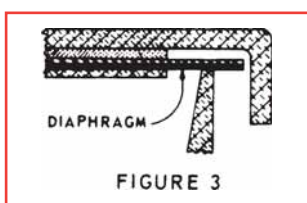
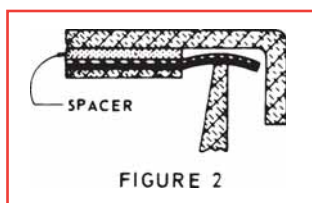
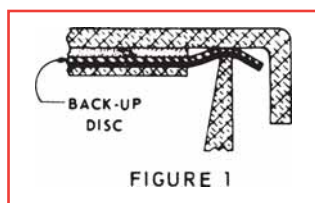

Figure 1 shows the relation of the vacuum pallet assembly to the seat when atmospheric and tank pressures are equal. The "wrap around" effect of the resilient diaphragm on the edge of the seat and the resulting high ratio of seating force to seating area affords a tight seal.

As the vacuum increases, the pallet begins to rise as shown in Figure 2. Because there is still a wraparound effect on the edge of the seat, good sealing is maintained. Teflon diaphragm memory and lapped seating surface further enhance sealing characteristics.

As increasing vacuum continues to lift the pallet (see Figure 3) the diaphragm is held in close proximity to the seat by the flat plane memory of the diaphragm material.

As set vacuum is reached, the diaphragm leaves the seat (see Figure 4) and the in-rushing vapor lifts the pallet even further.

The vacuum pallet lifts vertically permitting incoming air to enter the valve body. This relieves the vacuum condition.

In the closing cycle, incoming air on the pallet holds the Teflon diaphragm close to the pallet surface until peripheral seat contact is very near 100%, causing closure to occur at a value very close to the setting value.

VALVE SIZE	"B"	"D"	"E"	"G"	"H" Studs	"J" Holes	Diameter "BC"
2"	9	12	5 1/32	7/8	1	3	4 3/4
3"	11 1/8	14 7/8	5 31/32	13/16	1	3	6
4"	13 1/2	18	7 1/32	13/16	2	6	7 1/2
6"	16 11/16	22 3/16	10 11/32	3/4	4	4	9 1/2
8"	20 3/4	27 1/2	12 23/32	1	4	4	11 3/4
10"	24 15/16	32 15/16	14 29/32	1	6	6	14 1/4
12"	29 1/16	38 9/16	16 29/32	1	4	8	17

**NOTES:**

1. Connection size matches 125 lb. FF/150 lb. RF ANSI Flange.
2. Mounting holes straddle centerline except: 2" & 3" sizes, holes are on centerline.
3. Dimensions expressed in inches.

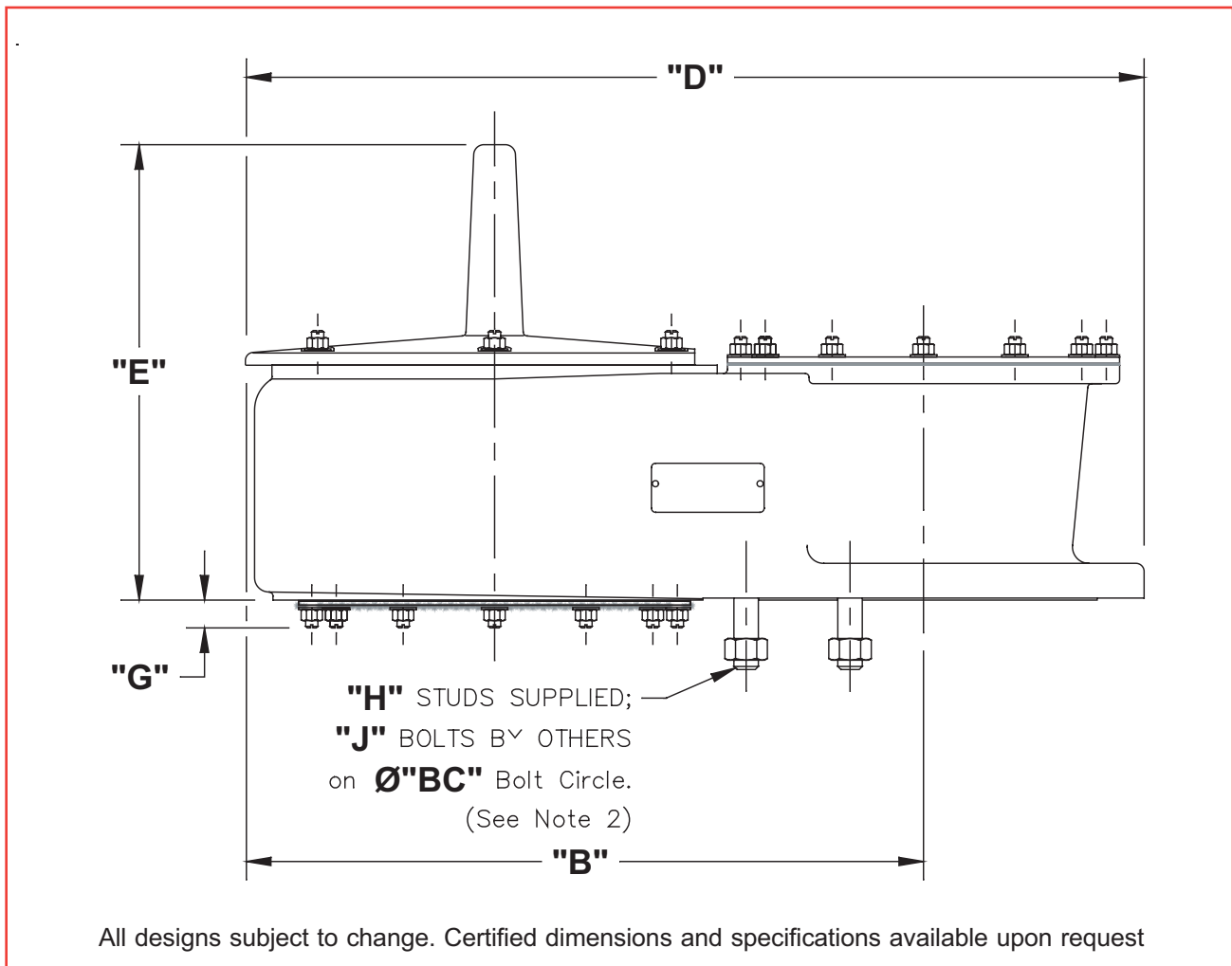

### MODEL NUMBER SELECTION:

The model number will consist of a base number 94110 followed by 8 digits which represent the options listed in the following tables.

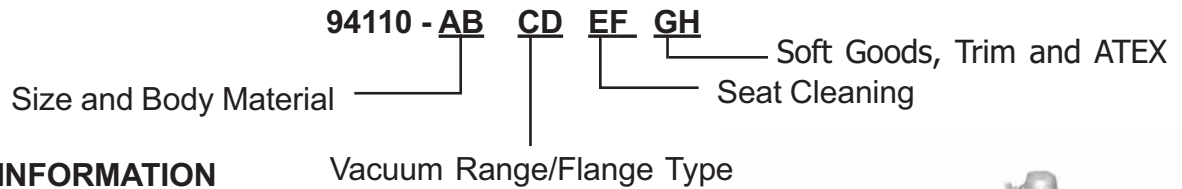

### ORDERING INFORMATION

Specify:

1. Model 94110 Vacuum Vent
2. Size, Body Material, and Service
3. Screwed or Flanged Connection on 2" and 3" Size
4. Vacuum Setting, if Other Than Normal
5. Optional Materials of Construction, as Required
6. Maximum static pressure
7. To Specify CE for Ordinary EU Locations use Table H2
8. ATEX Certification for Group IIB, IIA EU Locations use Table H1



### TABLE AB- SIZE AND BODY

OPTION (AB)	SIZE	CONNECTION	BODY MATERIAL
11	2"	THREADED	ALUMINUM
12	2"	FLANGED	ALUMINUM
13	3"	THREADED	ALUMINUM
14	3"	FLANGED	ALUMINUM
15	4"	FLANGED	ALUMINUM
16	6"	FLANGED	ALUMINUM
17	8"	FLANGED	ALUMINUM
18	10"	FLANGED	ALUMINUM
19	12"	FLANGED	ALUMINUM
31,41	2"	THREADED	CAST IRON, DUCTILE IRON
32,42	2"	FLANGED	CAST IRON, DUCTILE IRON
33,43	3"	THREADED	CAST IRON, DUCTILE IRON
34,44	3"	FLANGED	CAST IRON, DUCTILE IRON
35,45	4"	FLANGED	CAST IRON, DUCTILE IRON
36,46	6"	FLANGED	CAST IRON, DUCTILE IRON
37,47	8"	FLANGED	CAST IRON, DUCTILE IRON
38,48	10"	FLANGED	CAST IRON, DUCTILE IRON
39,49	12"	FLANGED	CAST IRON, DUCTILE IRON
51	2"	THREADED	CAST STEEL
52	2"	FLANGED	CAST STEEL
53	3"	THREADED	CAST STEEL
54	3"	FLANGED	CAST STEEL
55	4"	FLANGED	CAST STEEL
56	6"	FLANGED	CAST STEEL
57	8"	FLANGED	CAST STEEL
58	10"	FLANGED	CAST STEEL
59	12"	FLANGED	CAST STEEL
61	2"	THREADED	316 STAINLESS STEEL
62	2"	FLANGED	316 STAINLESS STEEL
63	3"	THREADED	316 STAINLESS STEEL
64	3"	FLANGED	316 STAINLESS STEEL
65	4"	FLANGED	316 STAINLESS STEEL
66	6"	FLANGED	316 STAINLESS STEEL
67	8"	FLANGED	316 STAINLESS STEEL
68	10"	FLANGED	316 STAINLESS STEEL
69	12"	FLANGED	316 STAINLESS STEEL

### TABLE C - FLANGE TYPE

OPT (C)	DESCRIPTION
0	ANSI FF
1	ANSI RF*
2	DIN 2633 RF PN 16*
3	DIN 2633 FF PN 16
4	JIS 10K FF
5	JIS 10K RF*

\* RF Not Available in Aluminum

### TABLE D - VACUUM RANGE

OPT (D)	DESCRIPTION
0	STANDARD SETTING- LEAD WEIGHTS
1	ABOVE STD. TO 2.9 OZ/IN2 - LEAD WEIGHTS
2	ABOVE 2.9 OZ/IN2 - LEAD WEIGHTS
3	STD. SETTING - 316SS WEIGHTS
4	ABOVE STD. TO 2.9 OZ/IN2 - 316SS WEIGHTS
5	ABOVE 2.9 OZ/IN2 - 316SS WEIGHTS

### TABLE E - SEAT & PALLET MATERIAL

Option (E)	Seat	Pallet
0	STD*	STD*
1	Teflon Coated SS	STD*
2	AL	STD*
+ 3	Phenolic	STD*
4	SS	STD*
+ 5	Teflon	STD*
A	STD*	316SS
B	Teflon Coated SS	316SS
C	AL	316SS
+ D	Phenolic	316SS
E	SS	316SS
+ F	Teflon	316SS

+ These Options Not Available with ATEX Models

### TABLE G & H - SOFTGOODS AND TRIM

For an ATEX Certified Valve choose Option H1

OPTION - G	DESCRIPTION	OPTION - H	DESCRIPTION
0	STD., FEP/N8090	0	STD. TRIM*
1	FEP (ALL)	1	ATEX/SS TRIM**
2	VITON (ALL)	2	CE / STD Trim*
3	PTFE/KN9007 (HI TEMP)		

\* See Materials of Construction

\*\* Includes stem, stem guides, side guides, nuts, bolts, screen and distribution plate

### TABLE F - CLEANING

Option F	Cleaning
0	Normal
1	LOX
2	LIN