



PRODUCT DATA SHEET

Model 609 Pneumatic Air Switch



316 Stainless Steel construction (switch element)

Standard 1/4" NPT supply and output connections

Constantly Engaged Magnetic Field

Trouble-Free Service - Assured by unique magnetic coupling, reliable performance and low cost

Direct or reverse acting operation

Fluorisilicon O-Ring Seals - for tight shut-off and long life

Large, easy to clean ports

The Omnitrol Model 609 Pneumatic Air Switch

The Omnitrol Pneumatic Liquid Level Control is a magnetically actuated precision-made on/off pneumatic instrument, which incorporates the use of a magnetically controlled switch actuator in conjunction with specific displacer configurations to provide liquid level indication and control. It is designed to operate under the corrosive and vibrating conditions associated with petrochemical industrial applications such as scrubber level control on level gas compressors for maintaining specific liquid levels and/or for high or low safety alarm indication.

The air switch can be supplied with any single stage (600 series) Omnitrol unit, with the exception of the Series 250. With the use of an adaptor kit it may be field retrofitted to any standard housing electric switch unit.

The air switch is mostly commonly used for applications such as those found in offshore drilling and in the area of gas compression and compressor protection. In addition, the air switch is well suited where electrical power is not available or where hazardous conditions exist. The positive magnetic coupling allows this unit to be used in areas of high vibration. The fast action and large port size provides fast response to liquid level changes. The three port, non-bleed design also conserves instrument air, or gas.

At low liquid level, the magnet arm is tilted upward. In a direct acting control as illustrated, the magnet arm forces the actuating screw to push down against the actuating arm, which forces the ball to seal against the supply port. The output port is open to exhaust. This position is held by the "Constantly Engaged Magnetic Field". As the liquid level rises, the inner magnet assembly rises and forces its way through the outer magnetic field. The sudden reversal of the magnetic field causes the magnet arm to move down which opens the supply pressure to the output and closes the exhaust.

The control can be made reverse acting by placing the actuating screw in the opening provided on the opposite side of the pivot. This will cause the control to increase output pressure on lowering liquid level. The magnet arm can be moved up and down by hand, and the optional supply and output gauges will indicate if the change from direct to reverse acting has been made correctly.

The output connection to the operation is always open, either to the exhaust or the air supply. See the reverse side for Table A, which illustrates the difference between direct and reverse acting.



PRODUCT DATA SHEET

Model 609 Pneumatic Air Switch

For a given set of conditions or specific gravity, pressure and temperature, the switching differential will be approximately 5% greater when the air switch is used in lieu of the standard electric switch.

Control Setting	Low Level	High Level
Air Switch set for direct acting	Supply port closed Exhaust port open	Supply port open Exhaust port closed
Air switch set for reverse acting	Supply port open Exhaust port closed	Supply port closed Exhaust port open

TABLE A

MATERIALS OF CONSTRUCTION:

Body and internal components: 316 SS
O-Ring seals: Fluorosilicone

CONNECTIONS:

1/4" NPT for supply and output connections- adaptable to standard chamber mount or top mount units

RATINGS:

Pressure ranges available - Instrument Air Supply 0-10 lbs. or 0-75 lbs. maximum pressure 100 PSIG

Maximum Ambient Temperature
-30° F to 150° F (-34° C to 65° C)

DIMENSIONS

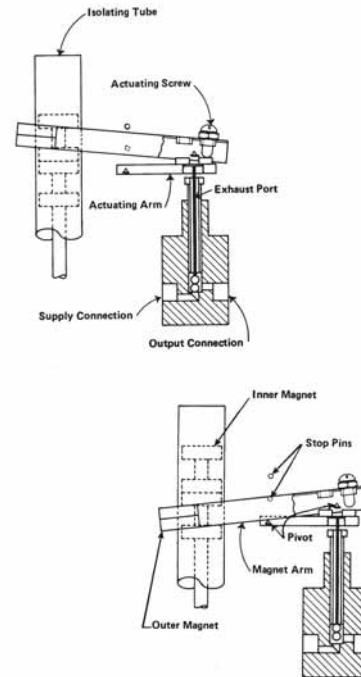
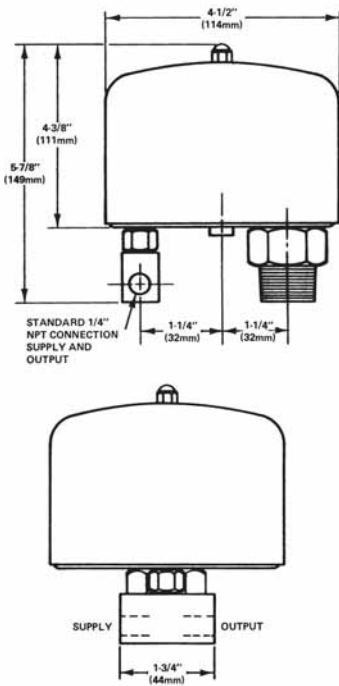

All designs subject to change. Certified dimensions and specifications available upon request.

INFORMATION REQUIRED TO ORDER:

Specify Model 609 Air Switch and provide complete description of the unit the Air Switch will be mounted on.

